

ASSEMBLY INSTRUCTIONS INSTRUCCIONES DE MONTAGE INSTRUCCIONES DE ENSAMBLAJE

1604 Scoot™

Personal Bookshelf
Étagère Personnelle
Biblioteca Personal

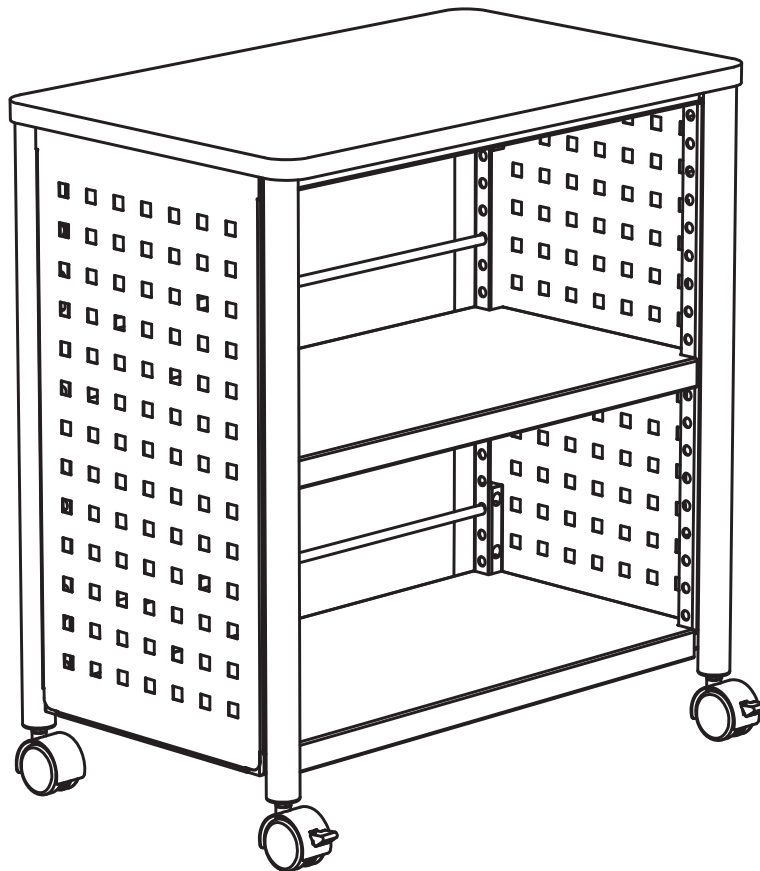

PRODUCT WARRANTY REGISTRATION is available online at: www.safcoproducts.com

• L'INSCRIPTION POUR LA GARANTIE DU PRODUIT est disponible sur l'Internet : www.safcoproducts.com

• EI REGISTRO PARA LA GARANTÍA DEL PRODUCTO está disponible en la Internet: www.safcoproducts.com

For questions or concerns, please call **1-800-664-0042**
available Monday-Friday 7:00 AM to 6:00 PM (Central Time) (English-speaking operators)

Si vous avez des questions pour poser ou les préoccupations pour exprimer, connecter **au 1-800-664-0042** de 7H00 à 18H00 (Heure centrale) (Opérateurs de langue anglaise)





Si usted tiene preguntas o preocupaciones, por favor llame **1-800-664-0042** de 7:00 AM a 6:00 PM (Hora Central) (Operadores que hablan inglés)

TOOLS REQUIRED: Phillips Screwdriver
OUTILS REQUIS: Tournevis à pointe cruciforme
HERRAMIENTAS REQUERIDAS: Destornillador Phillips®

Parts List / Liste des Pièces / Lista de Piezas

CODE / CODIGO	DESCRIPTION / DESCRIPTION / DESCRIPCIÓN	QUANTITY / QUANTITÉ / CANTIDAD	PART NO. / N° DE PIECE / NO. DE PIEZA
(A)	Bookshelf Top / <i>Bibliothèque Haut</i> / Estante Tapa	1	1604-01BL
(B)	Side Assembly / <i>Côté Prémonté</i> / lateral Pre-ensamblado	2	1600-02BL
(C)	Shelf Bar / <i>Support de tablette</i> / Soporte de Estante	4	1604-03BL
(D)	Shelf Bar Assembly / <i>Support de tablette prémonté</i> / Soporte de estante premontado	2	1604-04BL
(E)	Shelf / <i>Étagère</i> / Estante	2	1604-02BL
(F)	Book Bar / <i>livre Tringle</i> / libro Barra	2	1604-05BL

Hardware Pack / Paquet Matériel / Paquete Material:
1604-19NC

<p>G</p>  <p>Short Screw <i>Vis Court</i> Tornillo Corto Qty. / Qté. / Cant. 12 1600-22BL</p>	<p>H</p>  <p>Non-Locking Caster <i>Roue sans Frein</i> Rueda sin Freno Qty. / Qté. / Cant. 2 1874-25</p>
<p>I</p>  <p>Locking Caster <i>Roue avec Frein</i> Rueda con Freno Qty. / Qté. / Cant. 2 1874-26</p>	<p>J</p>  <p>Long Screw <i>Vis Longue</i> Tornillo Largo QTY. / Qté. / Cant.: 8 #1600-23BL</p>
<p>K</p>  <p>Spacer for Screw <i>Vis Entretoise</i> Espaciador Tornillo Qty. / Qté. / Cant. 8 1600-20BL</p>	

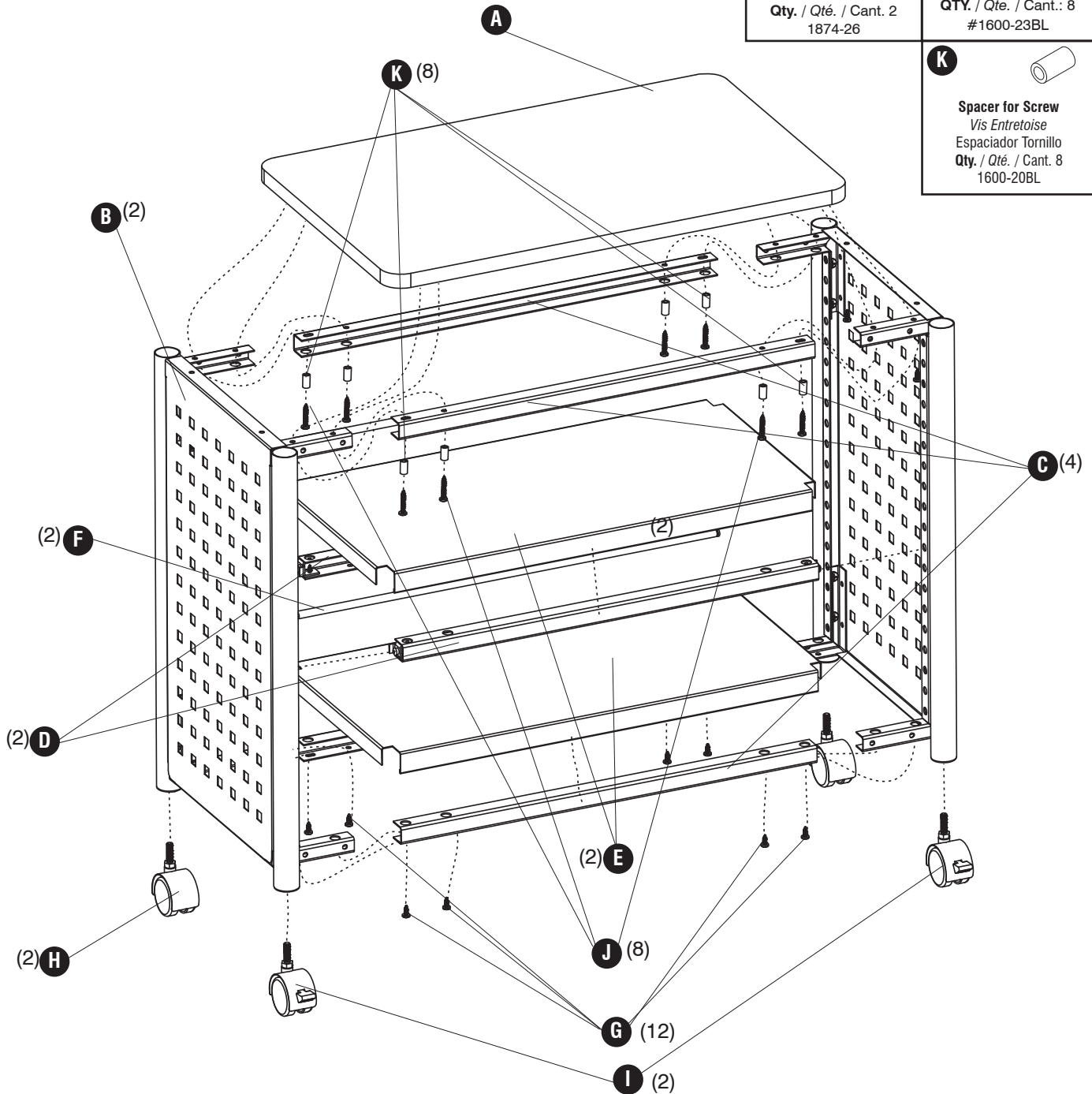

1

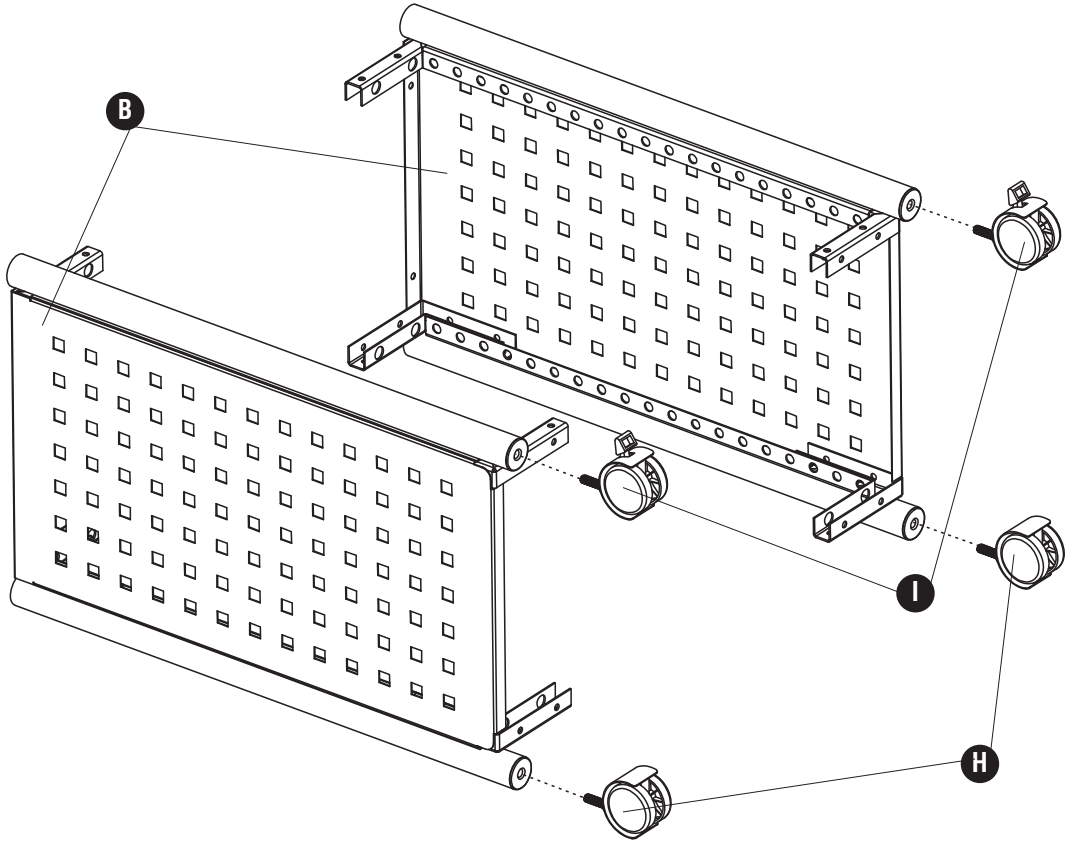

2

- G (4)
- J (8)
- K (8)

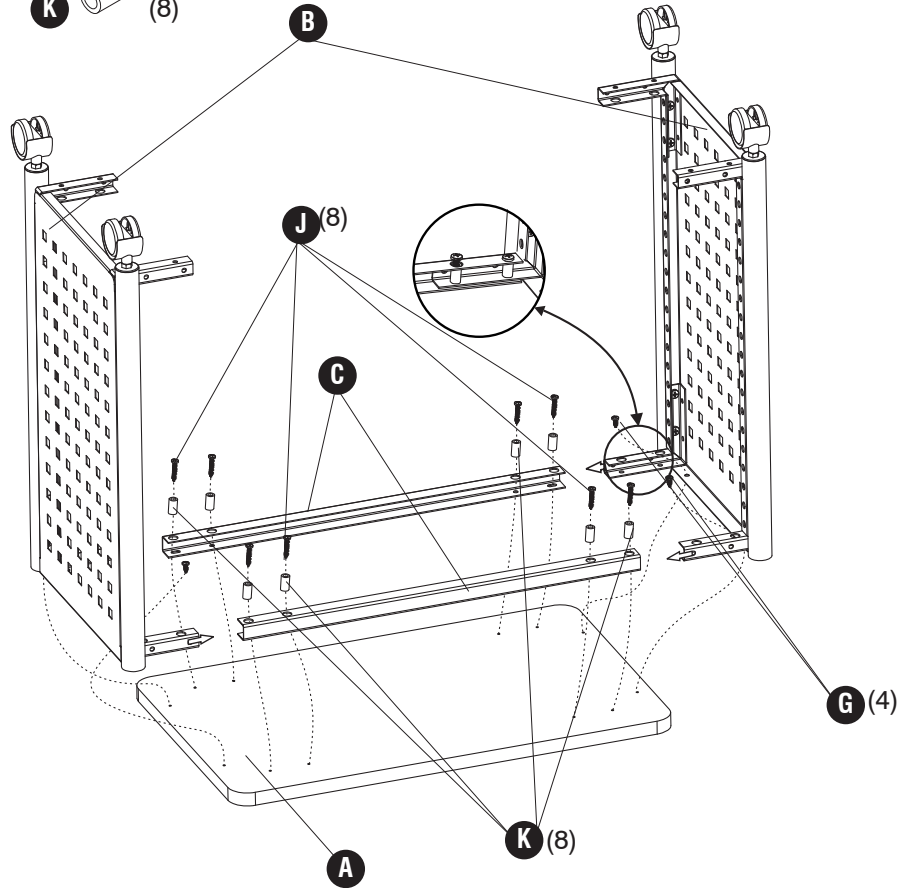

3 **G**  (8)

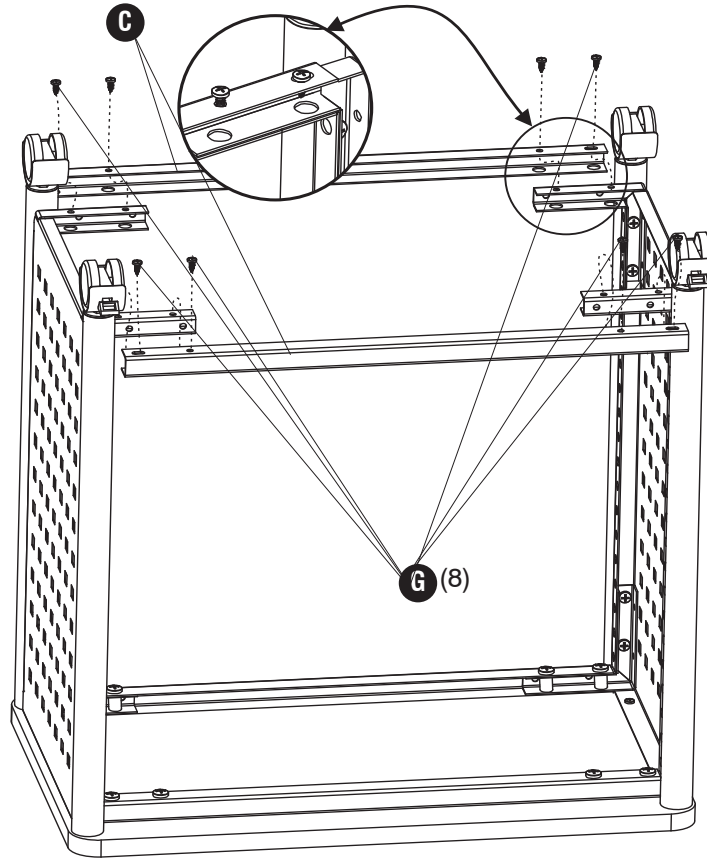

4

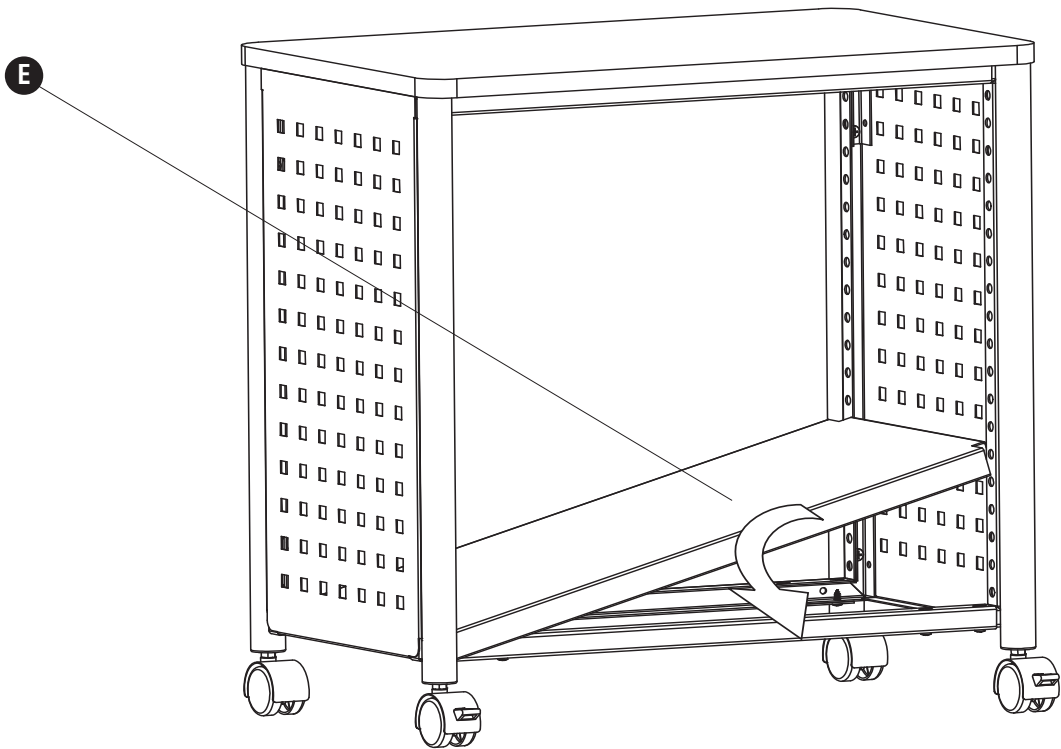

5

Tab should be in back
Tab devrait être à l'arrière
Oreja debe ser en la parte trasera

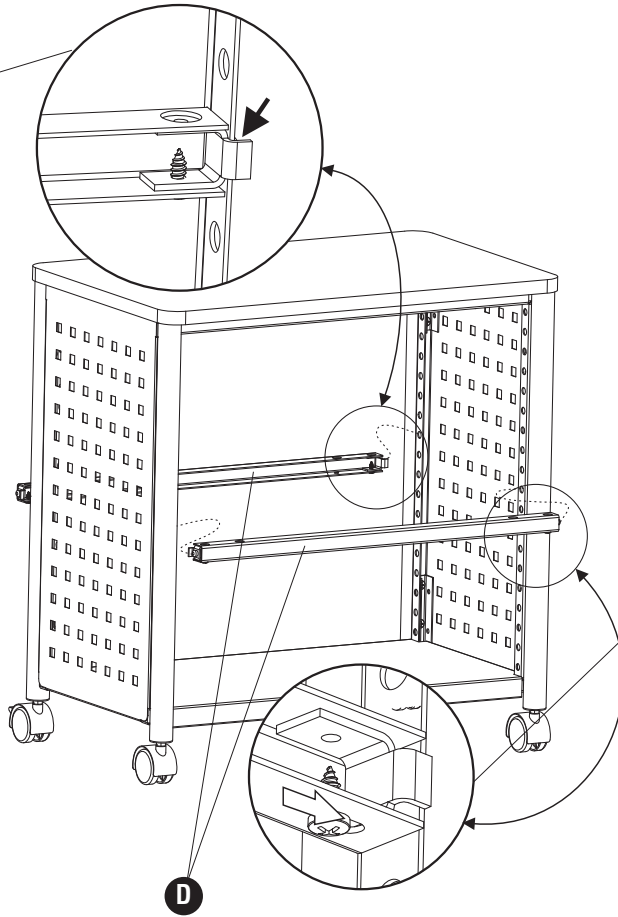

NOTE: On one side of the bar assembly, fully extend clip and tighten screw. Place clip in hole at desired height. Push clip on other side into hole and tighten screw.

NOTE: D'un côté de l'ensemble de barre, déployez entièrement agrafe et serrer la vis. Placez agrafe dans le trou à l hauteur désirée. Poussez agrafe de l'autre côté dans le trou et serrer la vis.

NOTA: A un lado del conjunto de barra, extienda completamente broche y apriete el tornillo. Coloque el broche en el orificio a la altura deseada. Empuje el broche de otro lado en el orificio y apriete el tornillo.

6

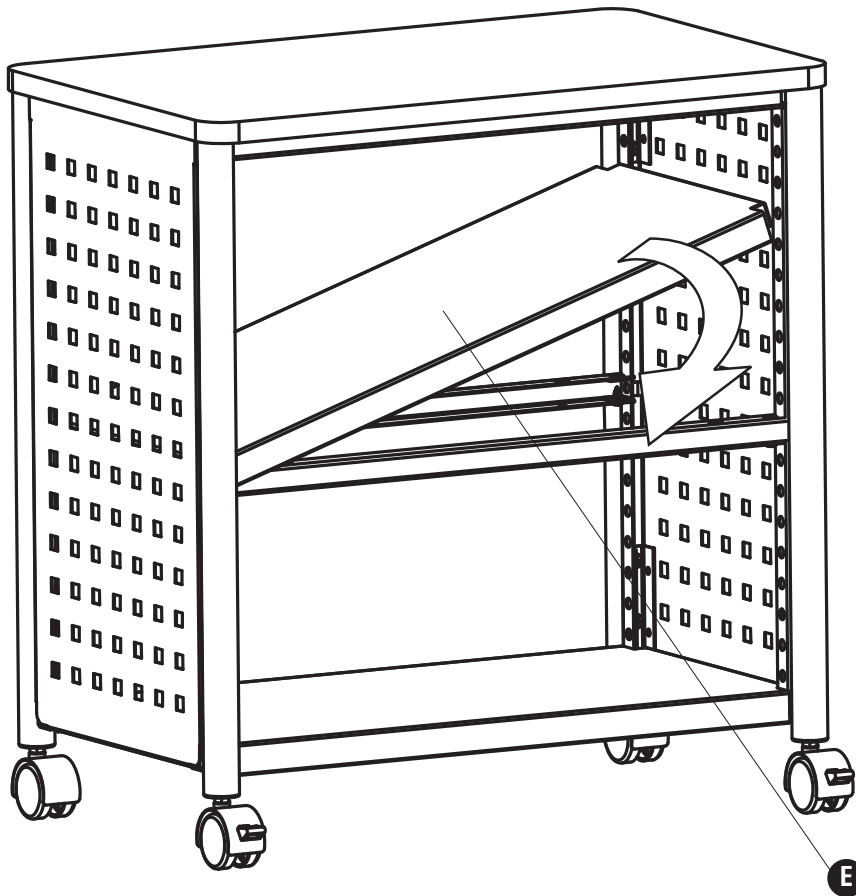

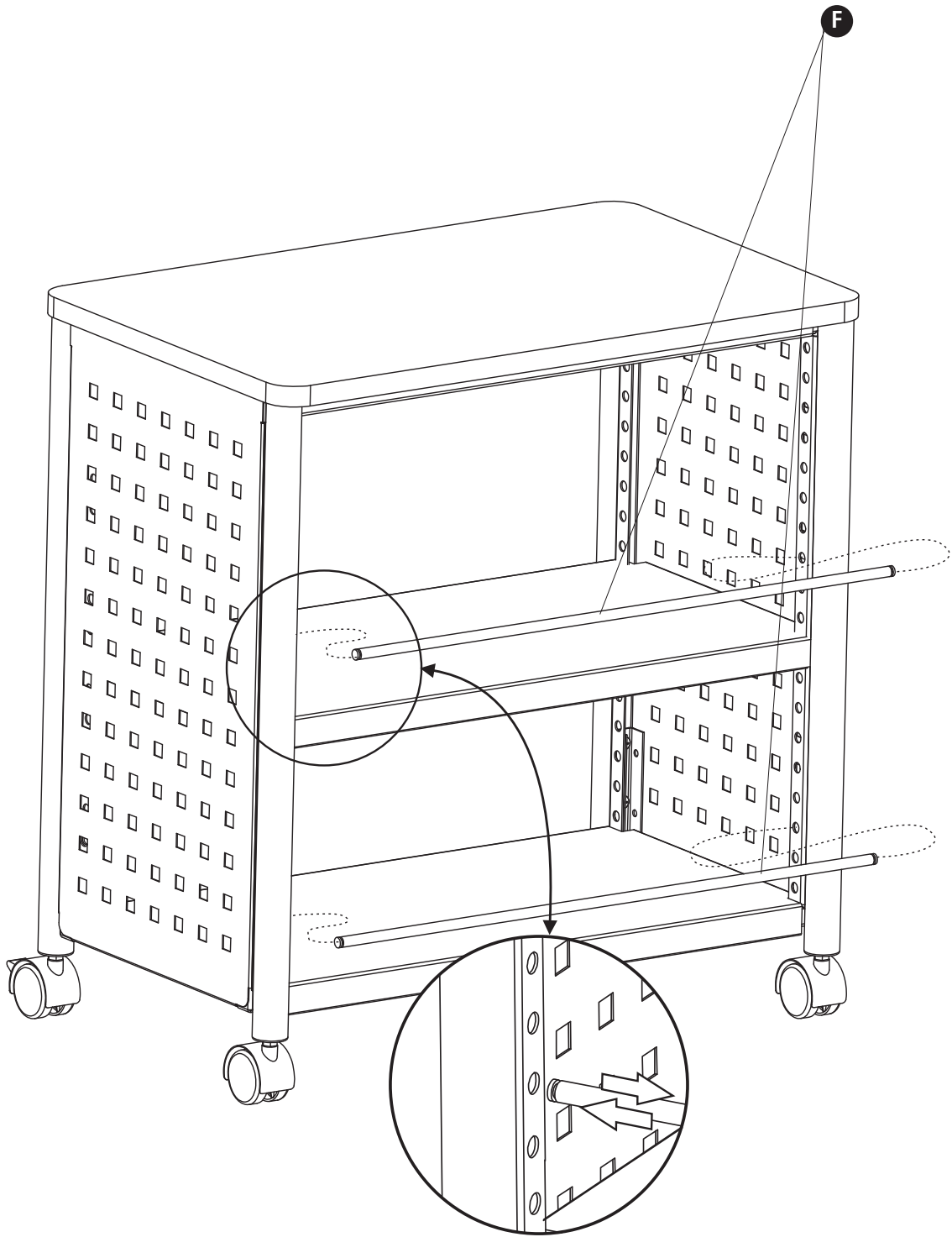

Place bars at desired height
Placer les tiges à la hauteur désirée
Coloque las barras a la altura deseada