

ASSEMBLY INSTRUCTIONS
INSTRUCCIONES DE MONTAGE
INSTRUCCIONES DE ENSAMBLAJE

1600
Scout™
Credenza
Bahut
Credenza

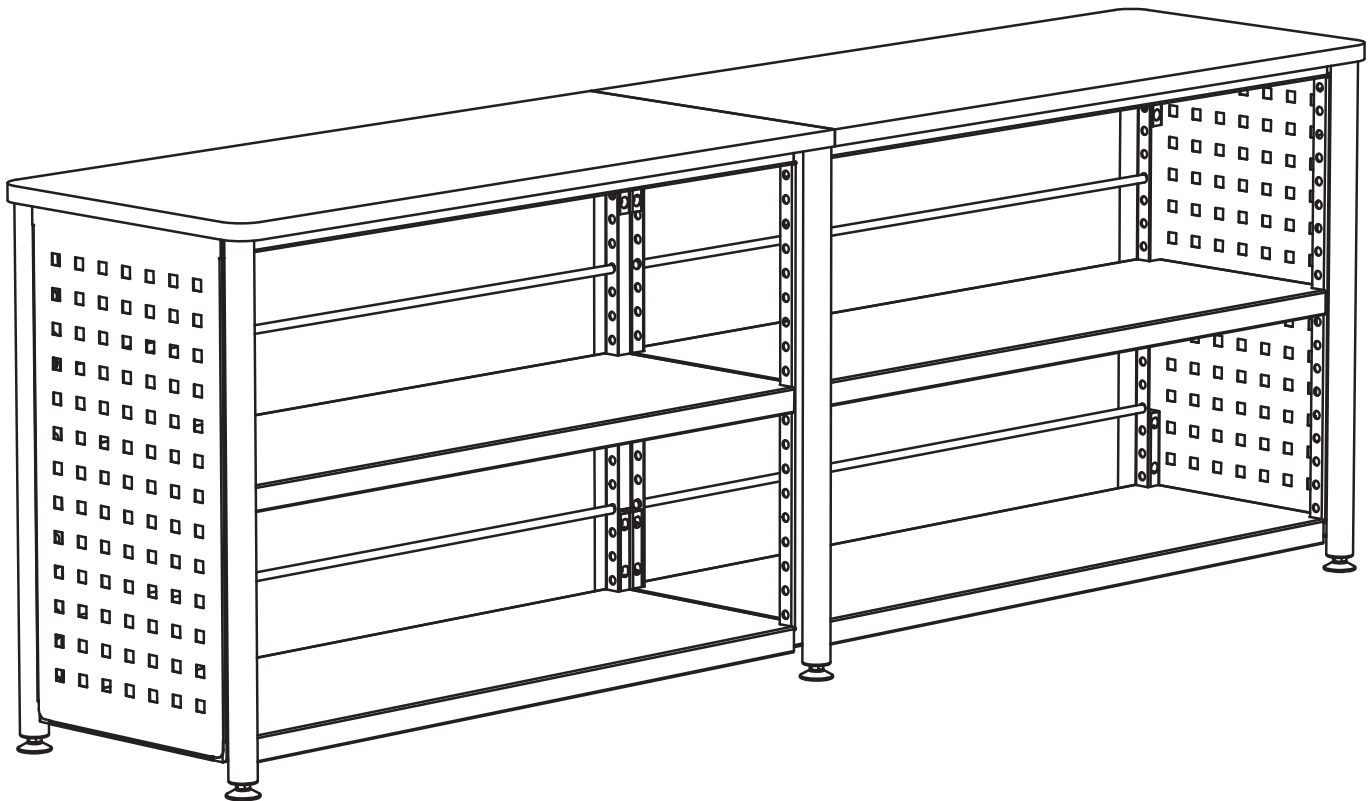

PRODUCT WARRANTY REGISTRATION is available online at: www.safcoproducts.com

• L'INSCRIPTION POUR LA GARANTIE DU PRODUIT est disponible sur l'Internet : www.safcoproducts.com

• EI REGISTRO PARA LA GARANTÍA DEL PRODUCTO está disponible en la Internet: www.safcoproducts.com

For questions or concerns, please call **1-800-664-0042**
available Monday-Friday 7:00 AM to 6:00 PM (Central Time) (English-speaking operators)

Si vous avez des questions pour poser ou les préoccupations pour exprimer, connecter **au 1-800-664-0042** de 7H00 à 18H00 (Heure centrale) (Opérateurs de langue anglaise)





Si usted tiene preguntas o preocupaciones, por favor llame **1-800-664-0042** de 7:00 AM a 6:00 PM (Hora Central) (Operadores que hablan inglés)

TOOLS REQUIRED: Phillips Screwdriver
OUTILS REQUIS: Tournevis à pointe cruciforme
HERRAMIENTAS REQUERIDAS: Destornillador Phillips®

Parts List / Liste des Pièces / Lista de Piezas

CODE / CODIGO	DESCRIPTION / DESCRIPTION / DESCRIPCIÓN	QUANTITY / QUANTITÉ / CANTIDAD	PART NO. / N° DE PIECE / NO. DE PIEZA
(A)	Top Assembly / Haut Prémonté / Pre-ensamblado Tapa	2	1600-01BL
(B)	Side Assembly / Côte Prémonté / lateral Pre-ensamblado	2	1600-02BL
(C)	Post Assembly / Prémonté Centre Poste / Centro de Pre-ensamblado poste	2	1600-03BL
(D)	Shelf Bar / Support de tablette / Soporte de Estante	8	1600-05BL
(E)	Shelf Bar Assembly / Support de tablette prémonté / Soporte de estante premontado	4	1600-06BL
(F)	Shelf / Étagère / Estante	4	1600-04BL
(G)	Book Bar / livre Tringle / libro Barra	4	1600-07BL

Hardware Pack / Paquet Matériel / Paquete Material:
1600-19NC

H		I	
Short Screw <i>Vis Court</i> Tornillo Corto Qty. / Qté. / Cant. 20 1600-22BL		Long Screw <i>Vis Longue</i> Tornillo Largo QTY. / Qte. / Cant.: 16 #1600-23BL	
J		K	
Foot Leveler <i>Levelleur pied</i> Nivelador pie Qty. / Qté. / Cant. 6 1600-24BL		Spacer for Screw <i>Vis Entretoise</i> Espaciador Tornillo Qty. / Qte. / Cant. 16 1600-20BL	

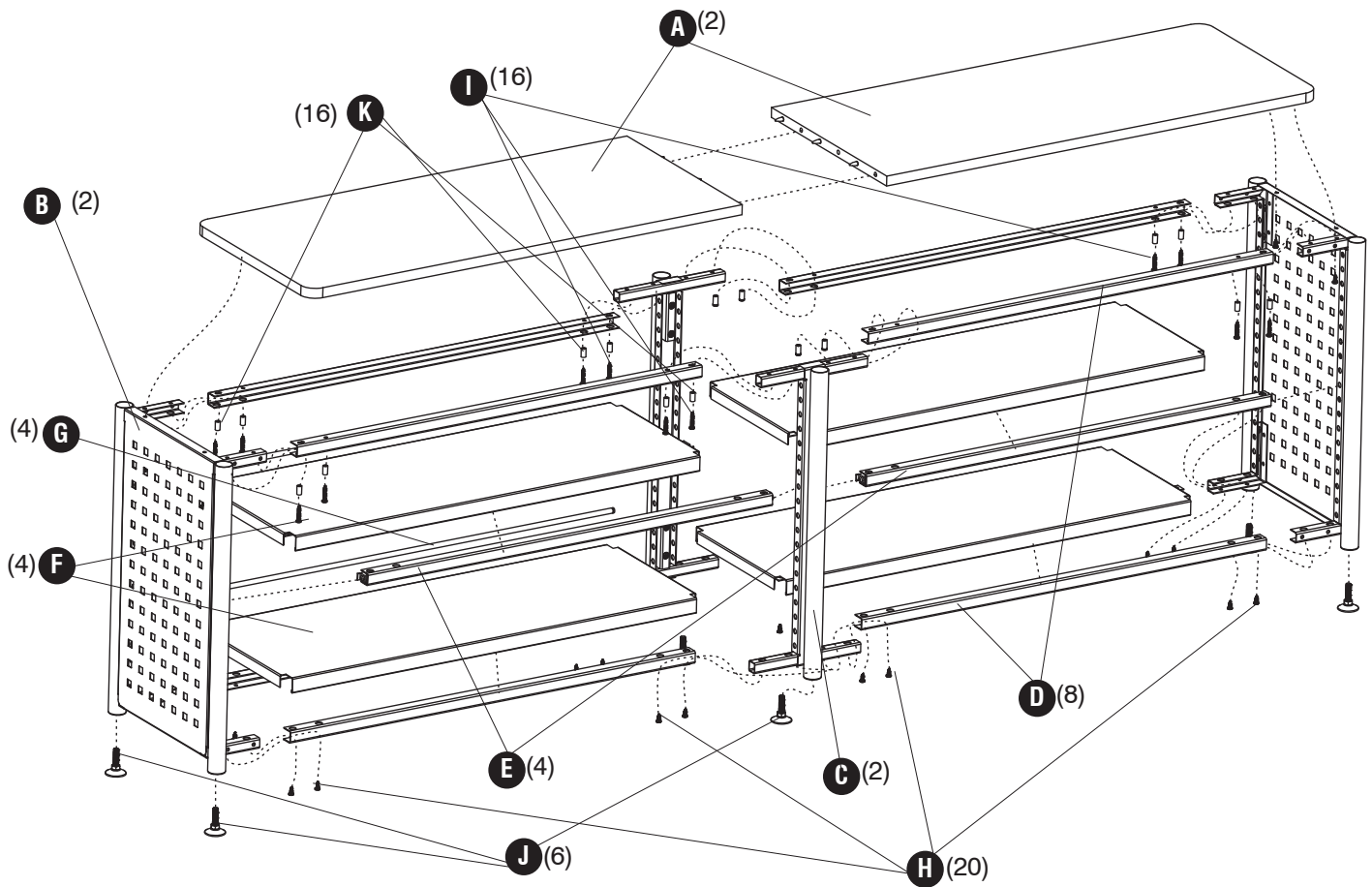

1 **J**  (6)

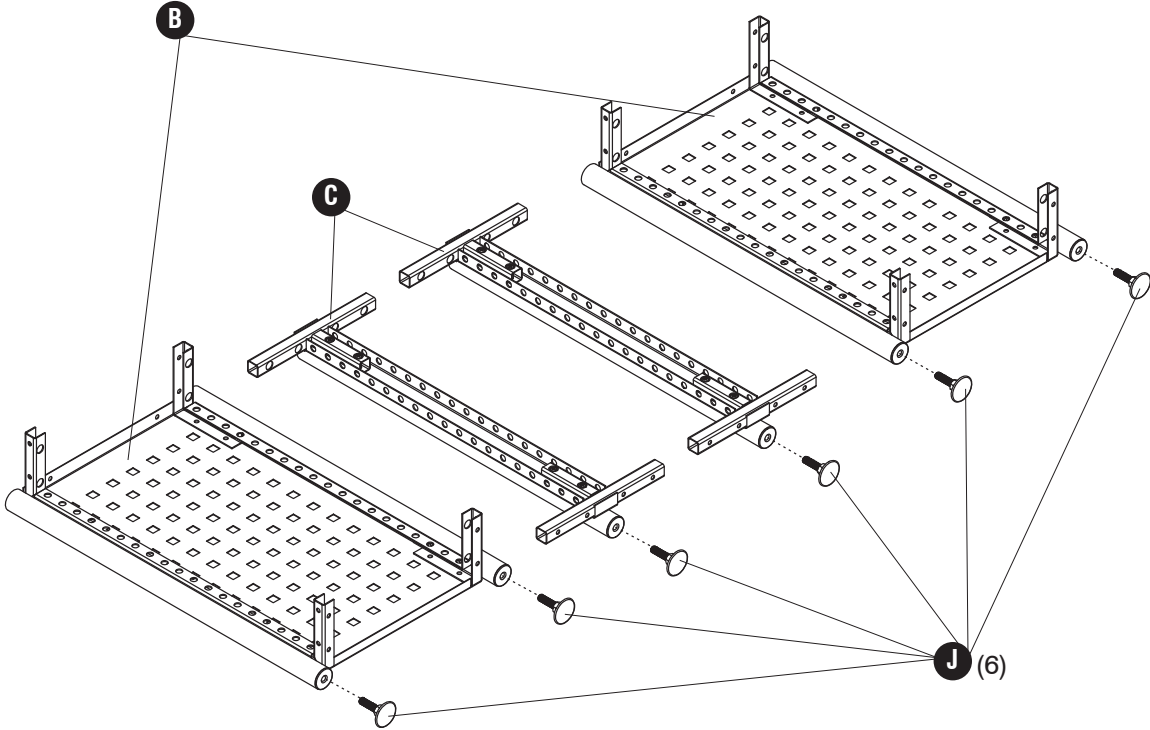

2

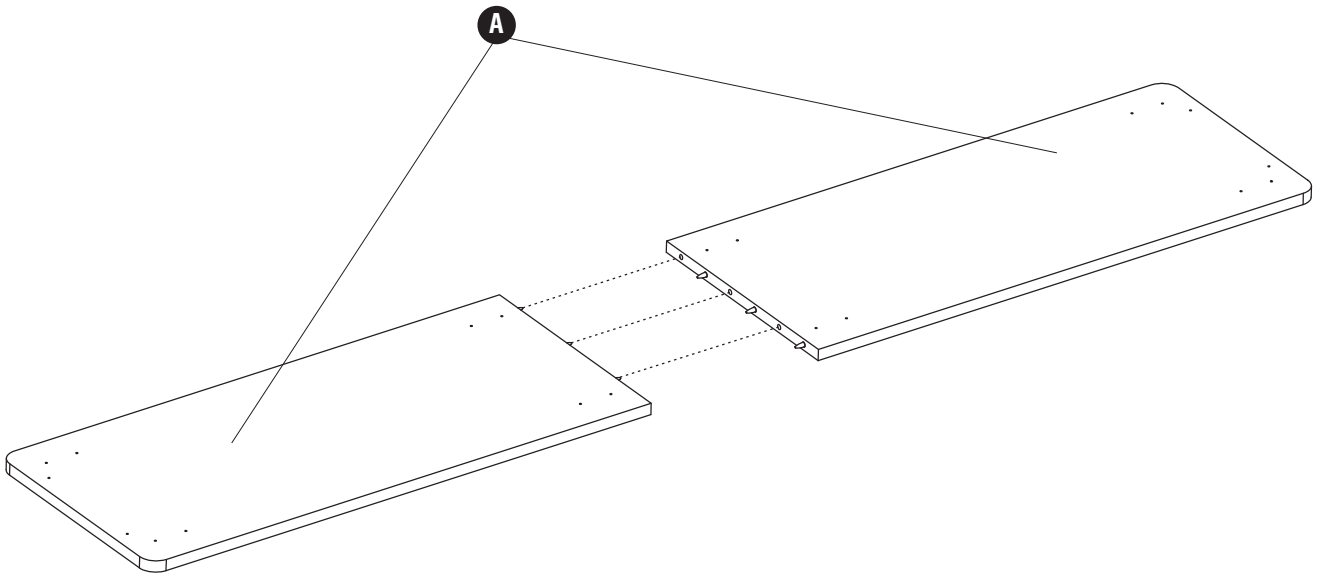

3 **I** (8) **K** (8) **H** (2)

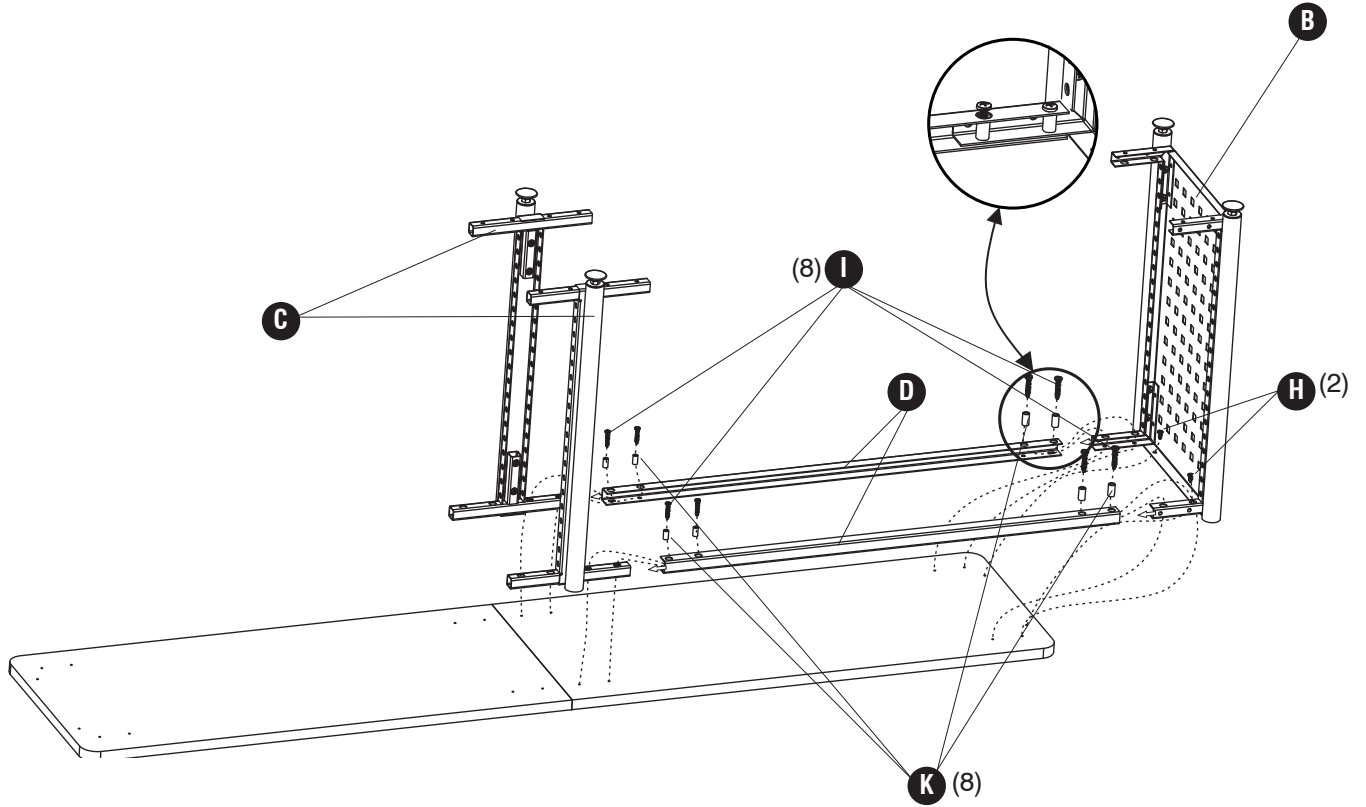

4 **I** (8) **K** (8) **H** (2)

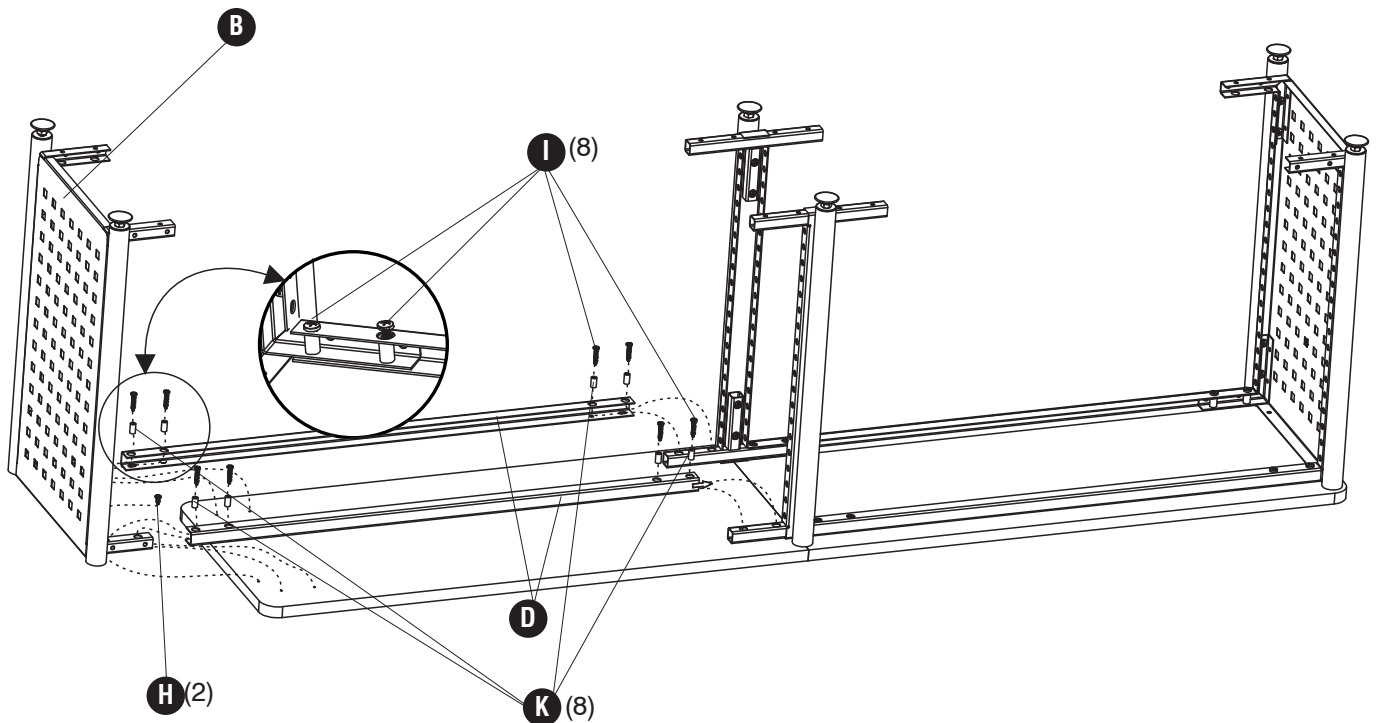

5 H  (16)

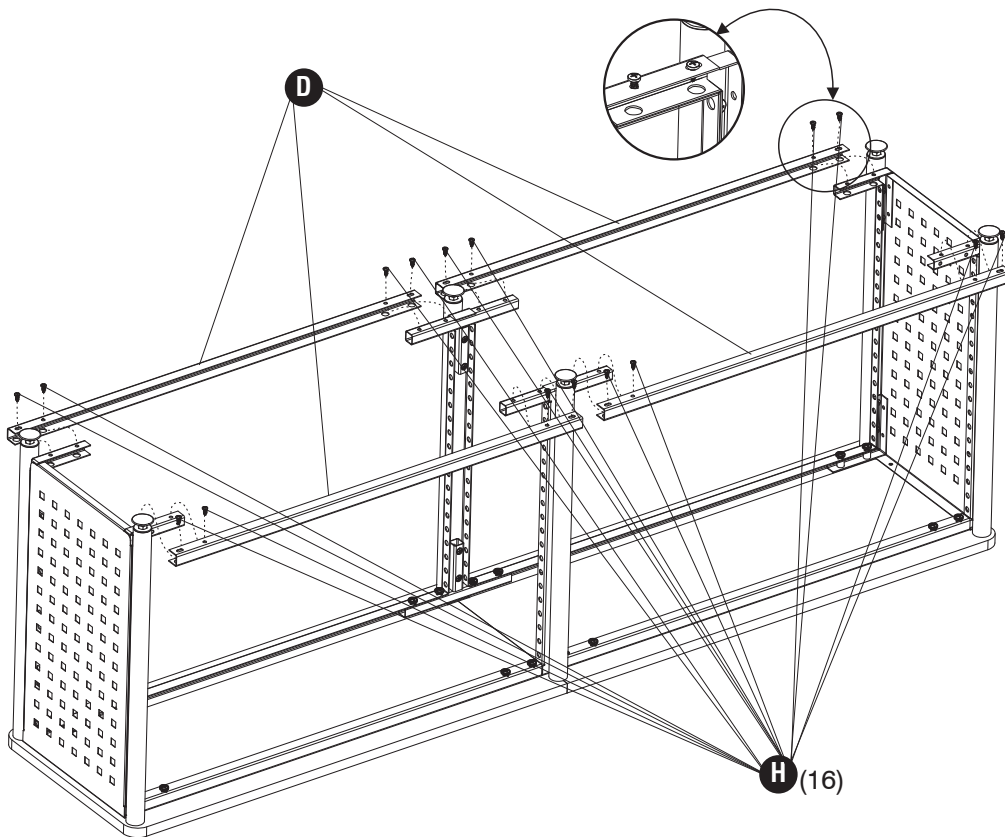

6

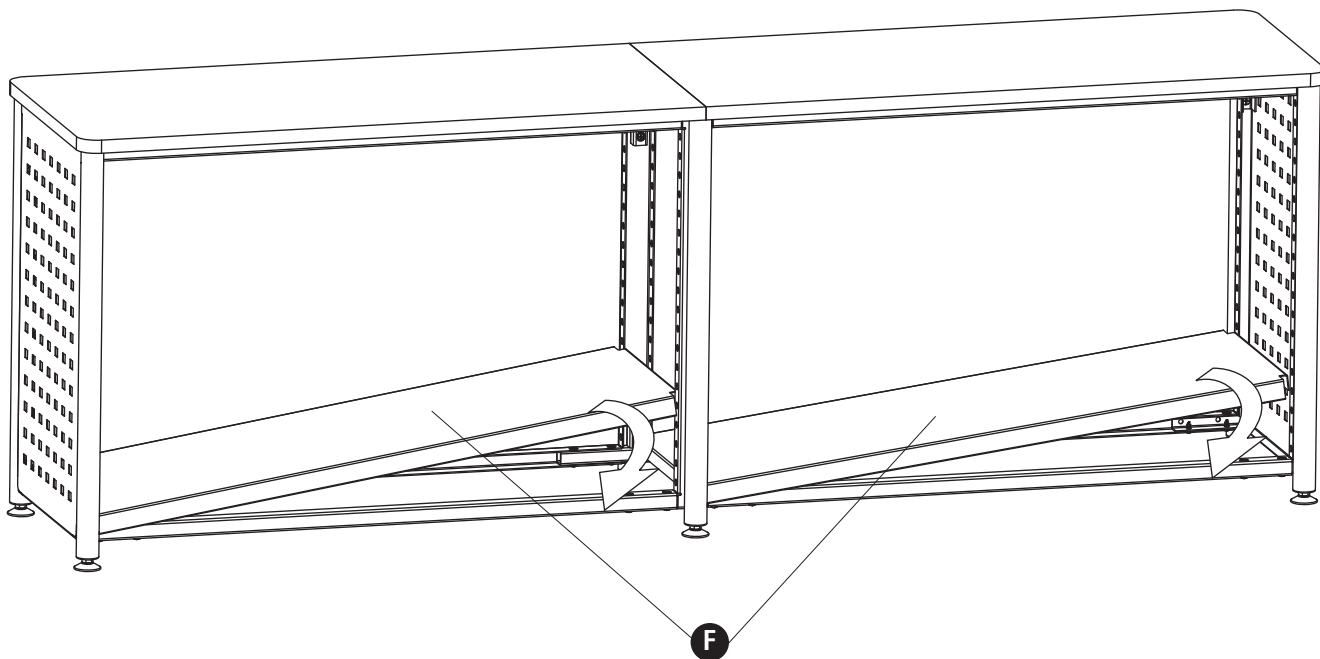

7

Tab should be in back

Tab devrait être à l'arrière

Oreja debe ser en la parte trasera

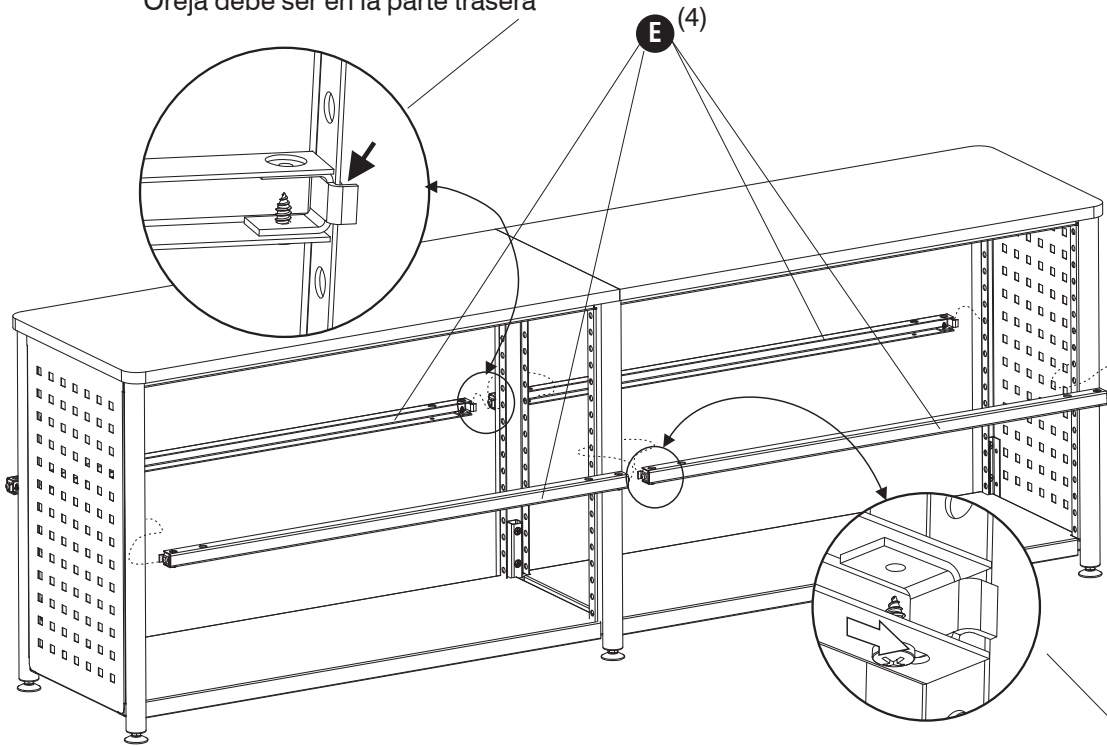

NOTE: On one side of the bar assembly, fully extend clip and tighten screw. Place clip in hole at desired height. Push clip on other side into hole and tighten screw.

NOTE: D'un côté de l'ensemble de barre, déployez entièrement agrafe et serrer la vis. Placez agrafe dans le trou à l hauteur désirée. Poussez agrafe de l'autre côté dans le trou et serrer la vis.

NOTA: A un lado del conjunto de barra, extienda completamente broche y apriete el tornillo. Coloque el broche en el orificio a la altura deseada. Empuje el broche de otro lado en el orificio y apriete el tornillo.

8

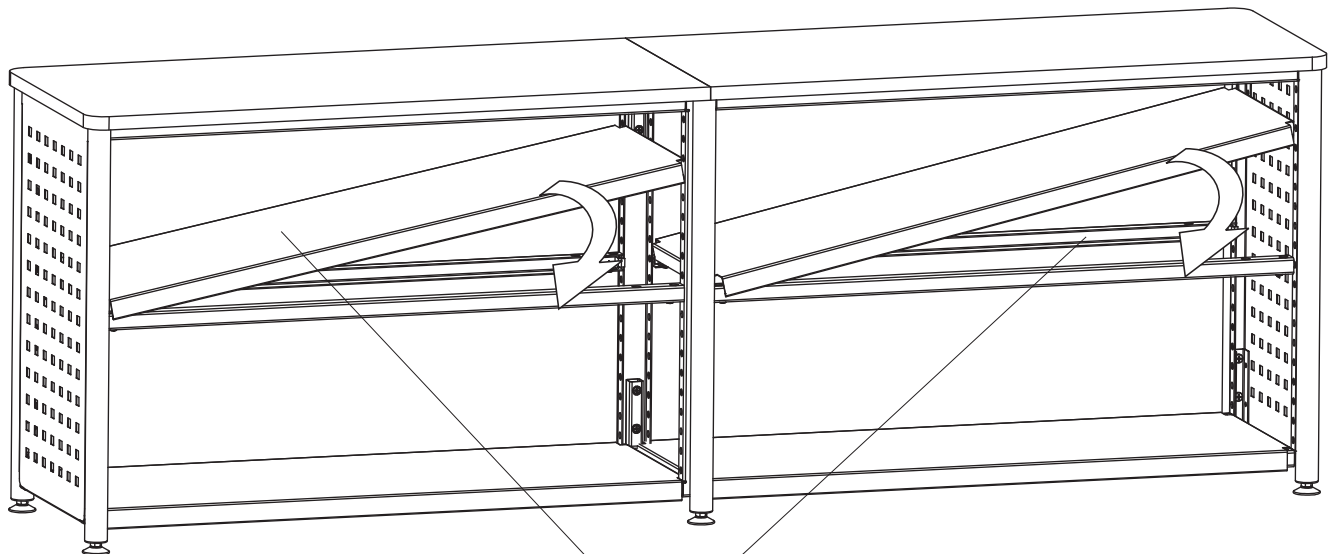

NOTE: If necessary, start shelf from below the shelf bar.

NOTE: Si nécessaire, amener l'étagère de entre les barres ci-dessous.

NOTA: Si es necesario, llevar la plataforma entre las barras de abajo.

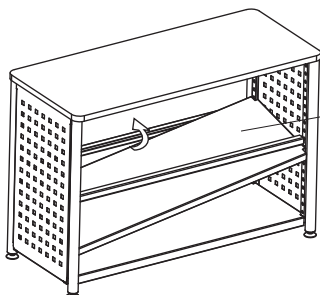

Place bars at desired height
Placer les tiges à la hauteur désirée
Coloque las barras a la altura de-seada

