

Model: TD202

- (1) Seat assembly
- (2) Front leg with arm (LH/RH)
- (1) Back leg assembly
- (1) Foot rest
- (2) Short brace (LH/RH)
- (2) Long brace (LH/RH)
- (1) Hardware pack

## TOOLS NEEDED

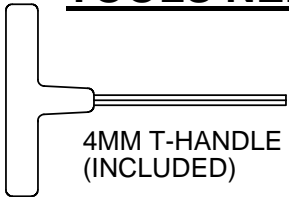

4MM T-HANDLE HEX KEY  
(INCLUDED)

Qty.	Description
2	A - .27 x 2-1/2 SOCKET WAFER "A"
20	B - .27 X 3 SOCKET WAFER "A"

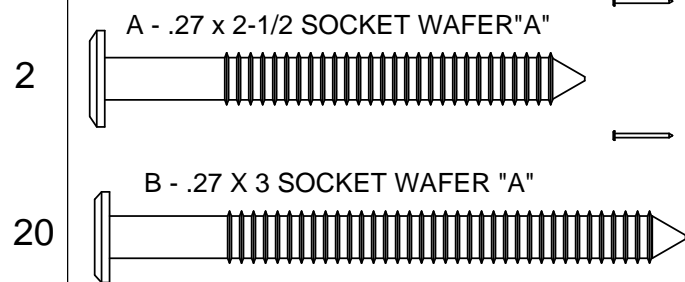

ASSEMBLY INSTRUCTIONS

**Step 1**  
Attach legs to the seat assembly and footrest with (8) 3" screws

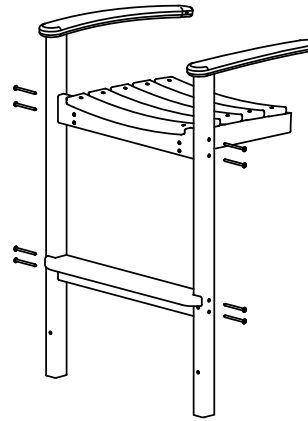

**Step 2**  
Attach arms to back leg assembly using (2) 2½" screws  
Attach back leg assembly to seat assembly using (4) 3" screws

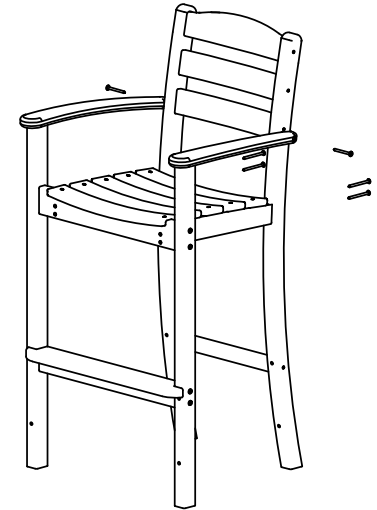

**Step 3**  
Attach braces between the front and back legs with the remaining (8) 3" screws.

**Note:** Compound angle cut on brace should be attached to the back leg

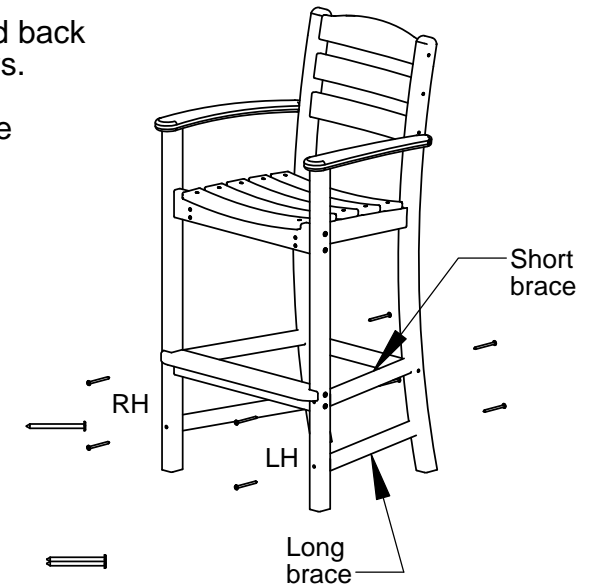
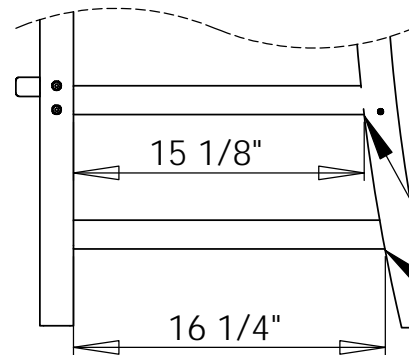

12° Compound angle cut with long edge on bottom  
\*Note: Braces are also RH and LH

ALL HARDWARE IS COATED STAINLESS STEEL

11/30/2012