



Intelligent Design™

Model: SBD24

- (1) Seat
- (1) Back
- (2) Front legs
- (2) Back legs
- (2) Arms
- (1) Footrest
- (1) Short brace
- (2) Side brace
- (2) Braces
- (1) Hardware pack

wings face forward

TOOLS NEEDED



7/16 Wrench
4mm HEX KEY, ALLEN, T-HANDLE
(INCLUDED)

Step 1

Lay seat on its side.
Attach front leg and back leg to seat. Flip seat around and do the other side. Uses (8) 1-7/8" bolts, nuts and washer

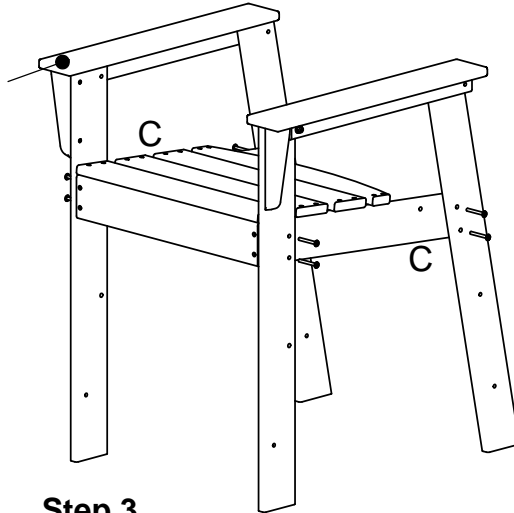

Step 2

Attach arms to front leg using (2) 2-1/4" bolts, nuts and washer
Attach braces to legs using (4) .27x2" screws

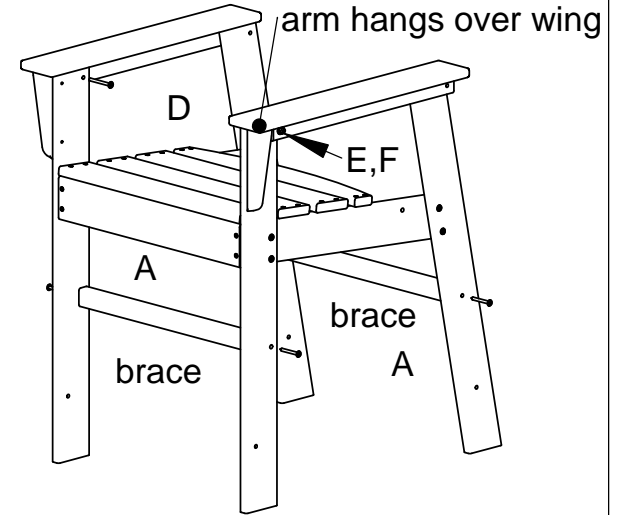

Step 3

Attach back to seat using (2) .27x2" screws
Attach back to rear leg using (2) .27x3" screws

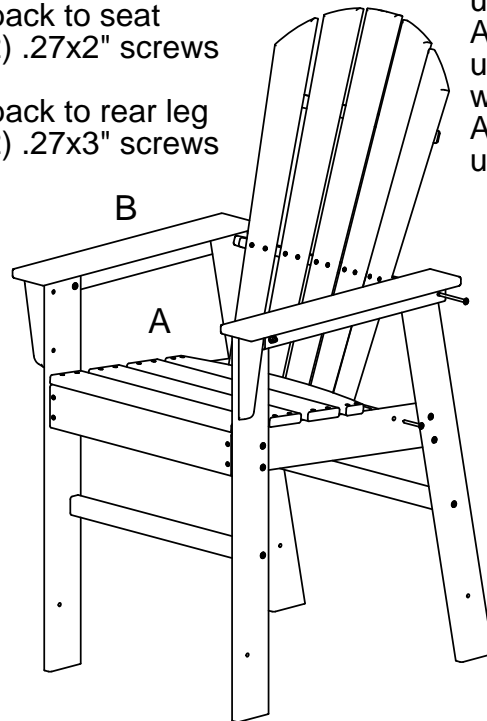

Step 4

Attach footrest to side braces using (2) .27x2" screws
Attach sidebrace to front legs using (2) 2-1/4" bolt, nut and washer
Attach short brace to sidebrace using (2) .27x3" screws

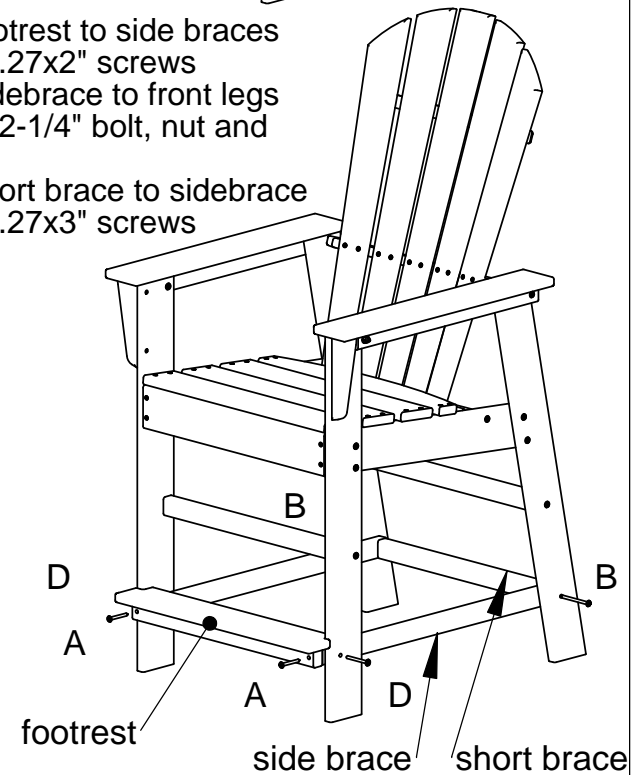

Qty. Description

8	A-.27 X 2 SOCKET WAFER A	
4	B-.27 X 3 SOCKET WAFER A	
8	C-1/4-20 X 1-7/8 WAFER SHCS	
4	D-1/4-20 X 2-1/4 WAFER SHCS	
12	E-1/4 FLAT WASHER	
12	F-1/4-20 NYLOCK NUT	