

Model: SBD16

- (1) Seat
- (1) Back
- (2) Front legs
- (2) Back legs
- (2) Arms
- (2) Braces
- (1) Hardware pack

Step 1
Lay seat on its side. Attach front leg and back leg to seat. Flip seat around and do the other side. Uses (8) 1-7/8" bolts, nuts and washer

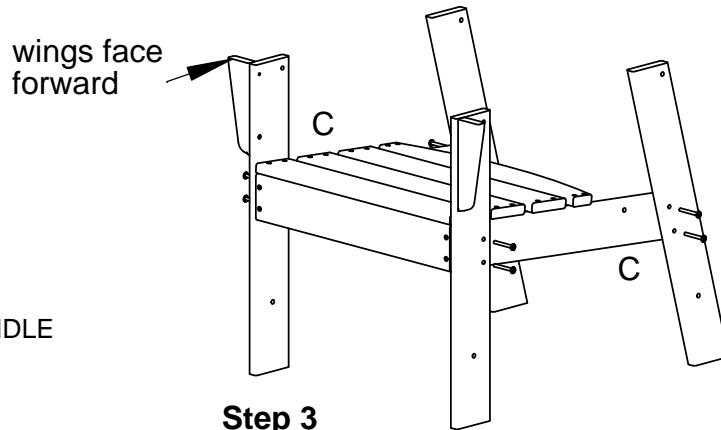

Step 2
Attach arms to front leg using (2) 2-1/4" bolts, nuts and washer

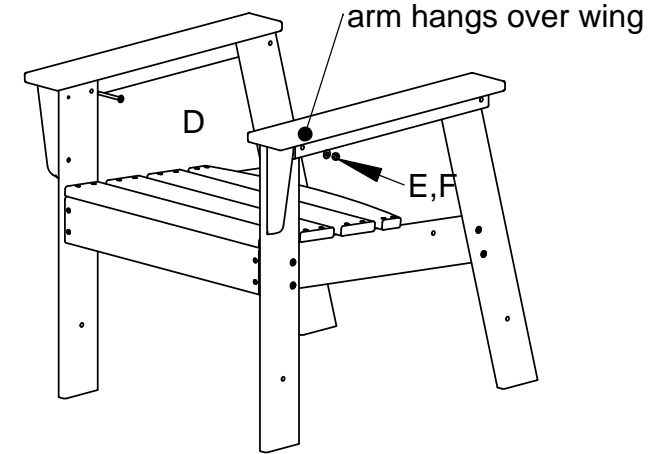

Step 3
Attach back to seat using (2) .27x2" screws

Attach back to rear leg using (2) .27x3" screws

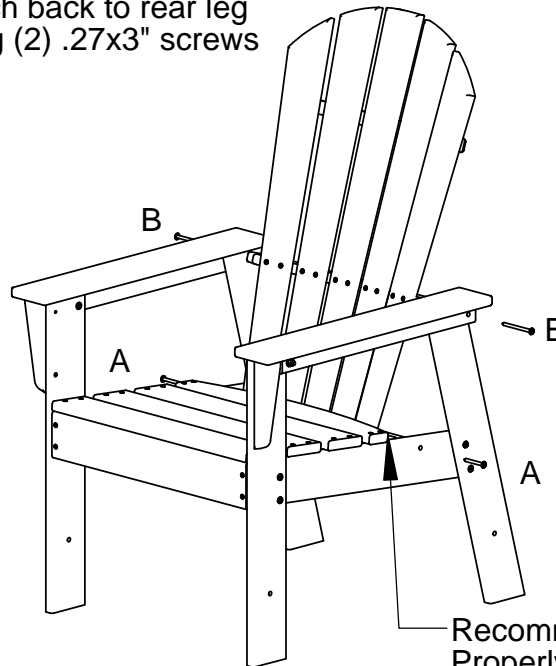

Step 4
Attach braces to legs using (4) .27x2" screws

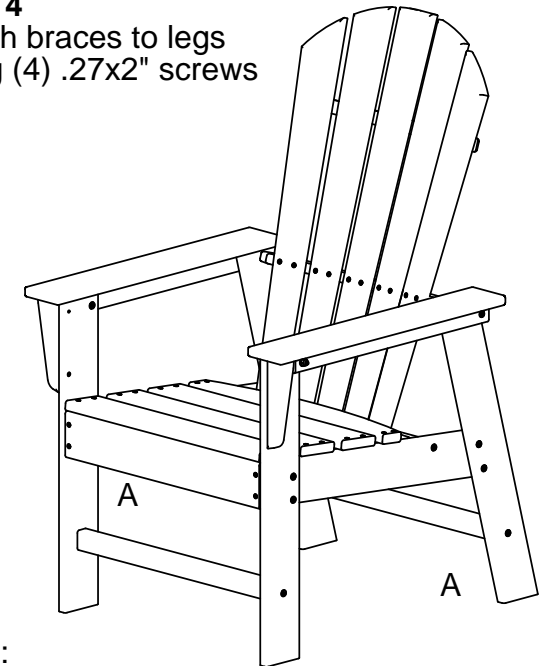

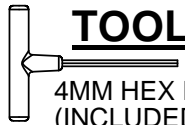

Recommended:
Properly support the back while attaching screws to ensure straight application

TOOLS NEEDED



4MM HEX KEY, ALLEN, T-HANDLE
(INCLUDED)
7/16 WRENCH

QTY. DESCRIPTION

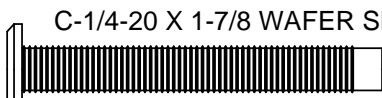
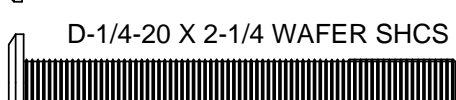
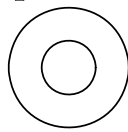
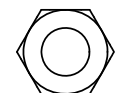
- | | | |
|----|---|-----------------------------|
| 6 |  | A-.27 X 2 SOCKET WAFER A |
| 2 |  | B-.27 X 3 SOCKET WAFER A |
| 8 |  | C-1/4-20 X 1-7/8 WAFER SHCS |
| 2 |  | D-1/4-20 X 2-1/4 WAFER SHCS |
| 10 |  | E-1/4 FLAT WASHER |
| 10 |  | F-1/4-20 NYLOCK NUT |