

Model: RKCB72

- (1) Hardware pack
- (2) Sideframes
- (1) Back assembly
- (1) Seat assembly

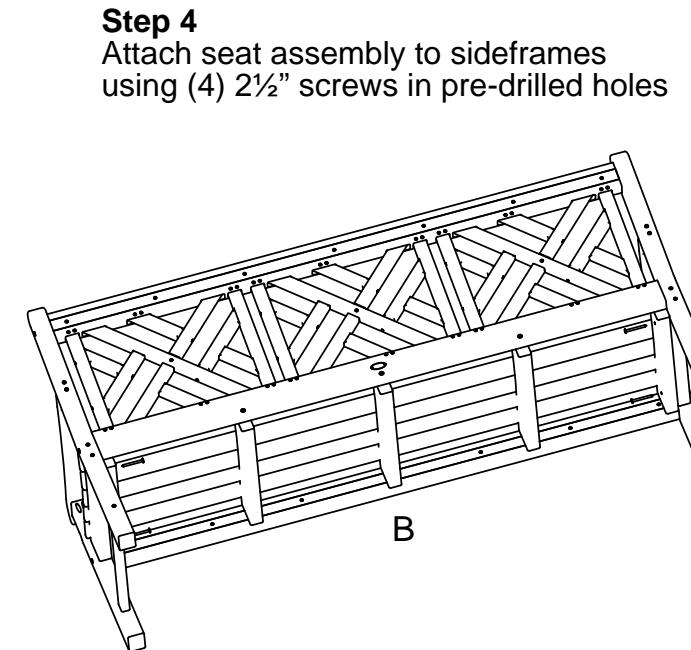

Qty.	Description
9	A - .27 X 3 SOCKET WAFER A
4	B - .27 X 2-1/2 SOCKET WAFER A

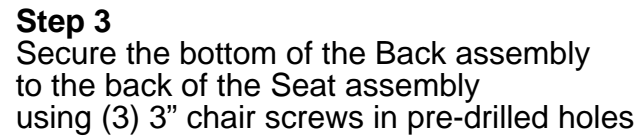
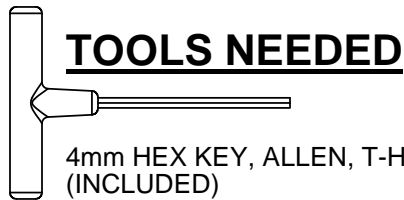
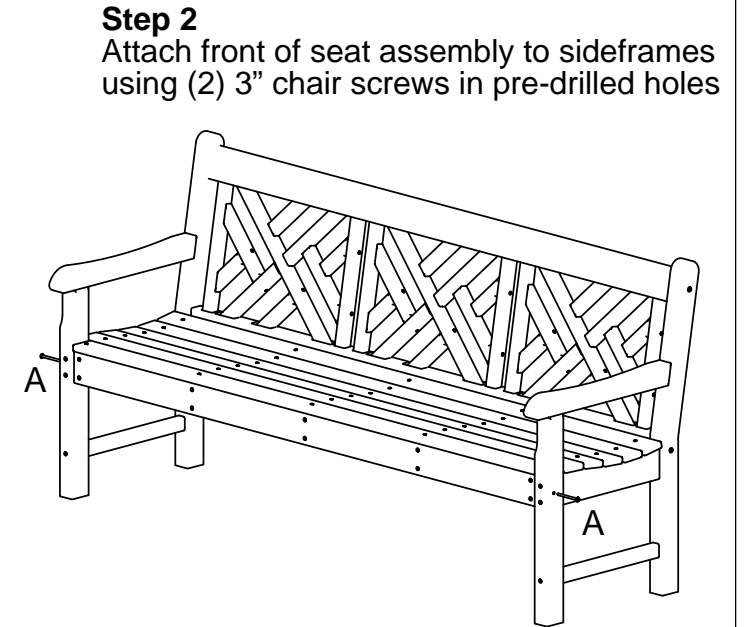
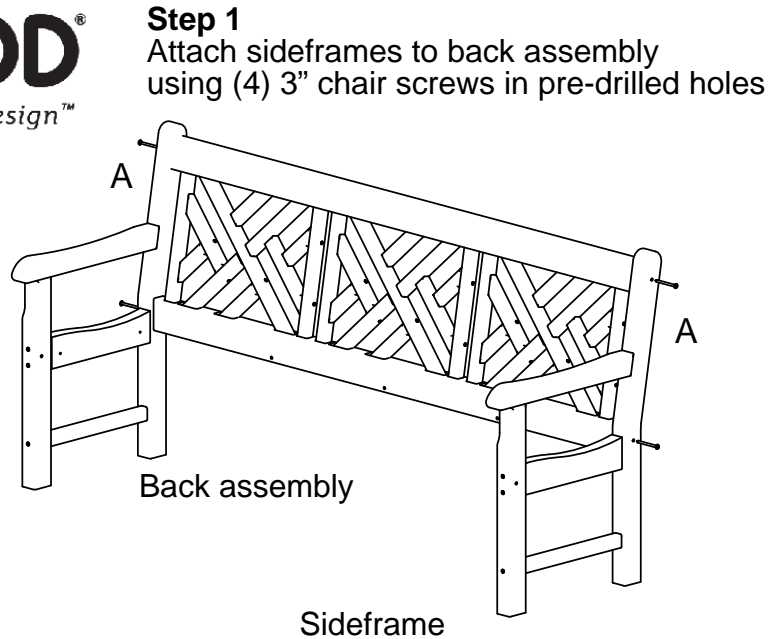