

## INITIAL PHASE

Model: PH53

- (4) Seats
- (2) Leg frames
- (1) Table top
- (1) Hardware pack

### TOOLS NEEDED

- #2 Phillips bit
- #2 Square bit
- Screw gun
- 7/16 wrench
- Hammer

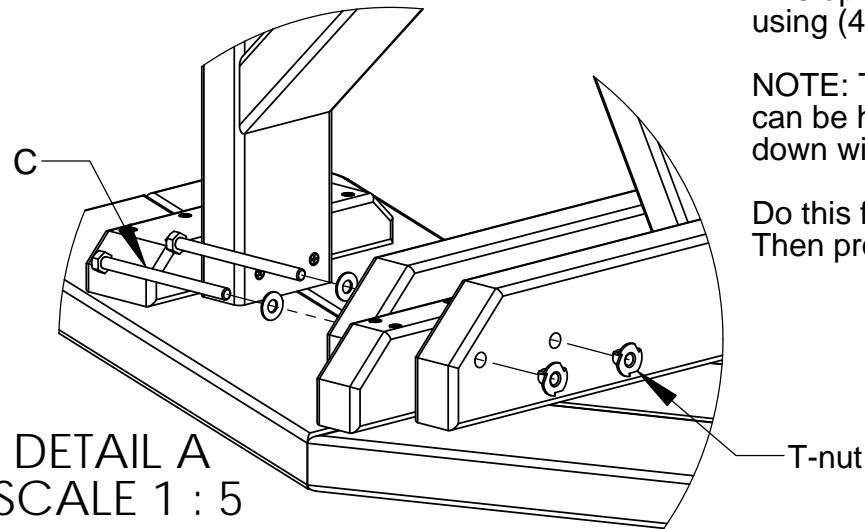

### STEP 1

Line up holes and attach Seat to Leg frame using (4) bolt with washer and T-nut

NOTE: T-nut will only fit on one side and can be hammered in place before securing down with the bolt

Do this for all 4 seats  
Then proceed to final phase

### STEP 2

Attach Seat to Leg frame using (2) 2½" screws

Qty.	Description
8	A - 8 X 2-1/2 PHIL FLAT SCREW
4	B - 10 X 3-1/2 SQ FLAT DECK SS
8	C - 5/16-18 X 4-1/2 HEX CAP BOLT SS
8	5/16 X 3/4 OD FLAT WASHER
8	5/16-18 X 3/8 T-NUT 3 PRONG SS

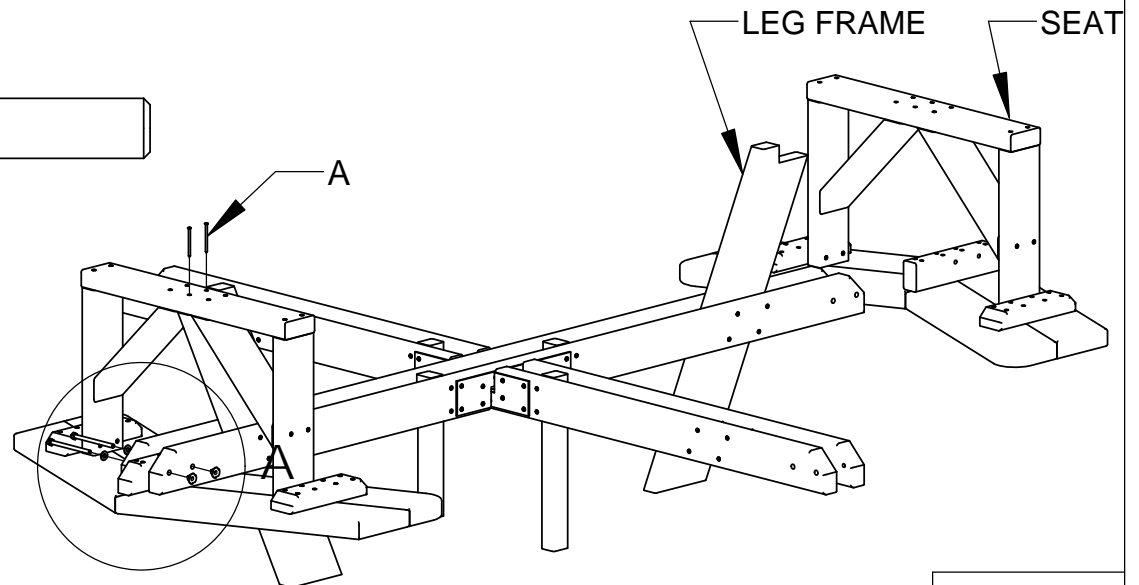

Model: PH53

## FINAL PHASE

**STEP 3:**  
Set the upper seat section  
over the lower seat section.

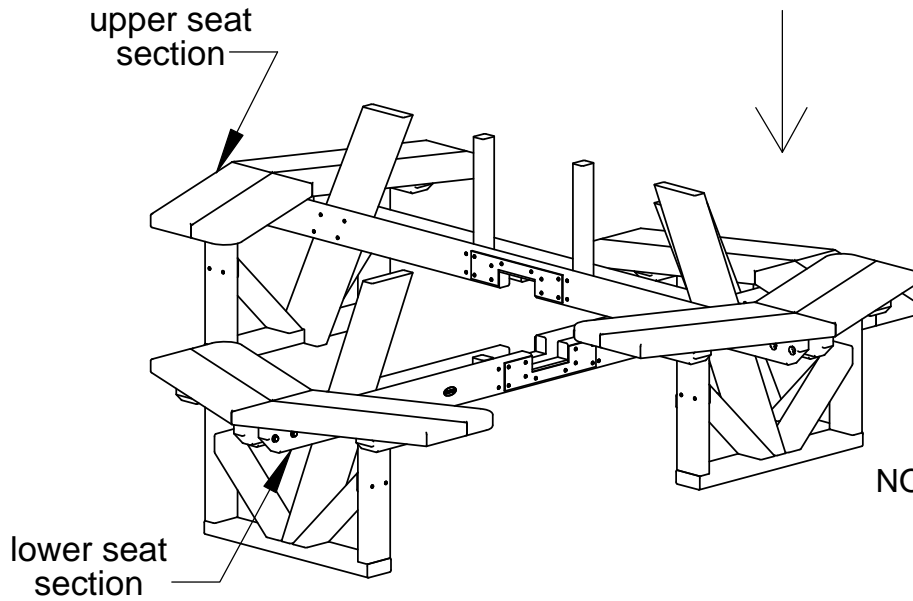

**STEP 4:**  
Set top assembly down onto  
leg/seat base and center it up.

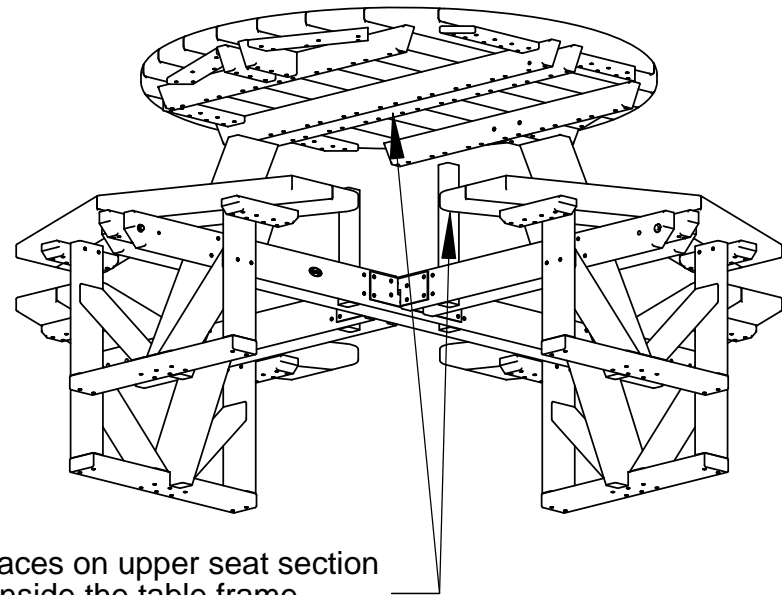

**STEP 5:**  
Use square head 3-1/2"  
screw to tie the top to each  
of the legs, 4 screws total.

