



Intelligent Design™

Model: PBB72

- (2) Leg assembly
- (1) Seat
- (1) Brace
- (1) Hardware pack

### TOOLS NEEDED

- Hammer
- 7/16" socket drive
- 1/2" socket drive

**Step 1**  
Insert T-nuts in both leg assemblies

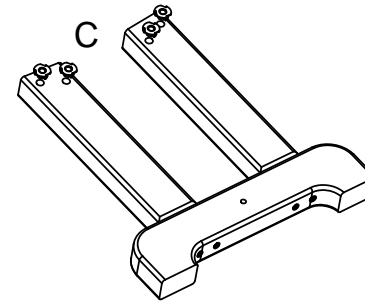

**Step 2**  
Lay Seat upside down.  
Attach leg assemblies to seat  
using (8) 3" bolts and nuts  
**Note: Side frames attach to the  
inside of the seat frame.**

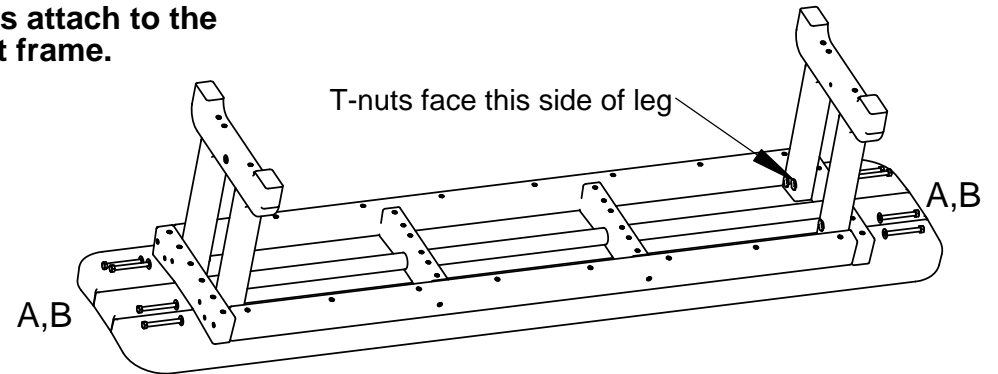

Qty.	Description
8	A-5/16-18 X 3 HEX CAP SCREW
8	B-5/16 X 3/4 OD FLAT WASHER
8	C-5/16-18 X 3/8 T-NUT 3 PRONG SS
2	D-1/4 FLAT WASHER
2	E-1/4 X 3 HEX LAG SCREW

**Step 3**  
Attach brace using (2) 3" lags and washers

