

Model: PBB48

- (2) Leg assembly
- (1) Seat
- (1) Brace
- (1) Hardware pack

TOOLS NEEDED

- Hammer
- 7/16 socket drive
- 1/2 socket drive

Step 1
Lay seat assembly upside down.
Attach leg assemblies to seat assembly
using (8) 3" 5/16 cap screws and T-Nuts

Note: Side frames attach to the
inside of the seat frame.

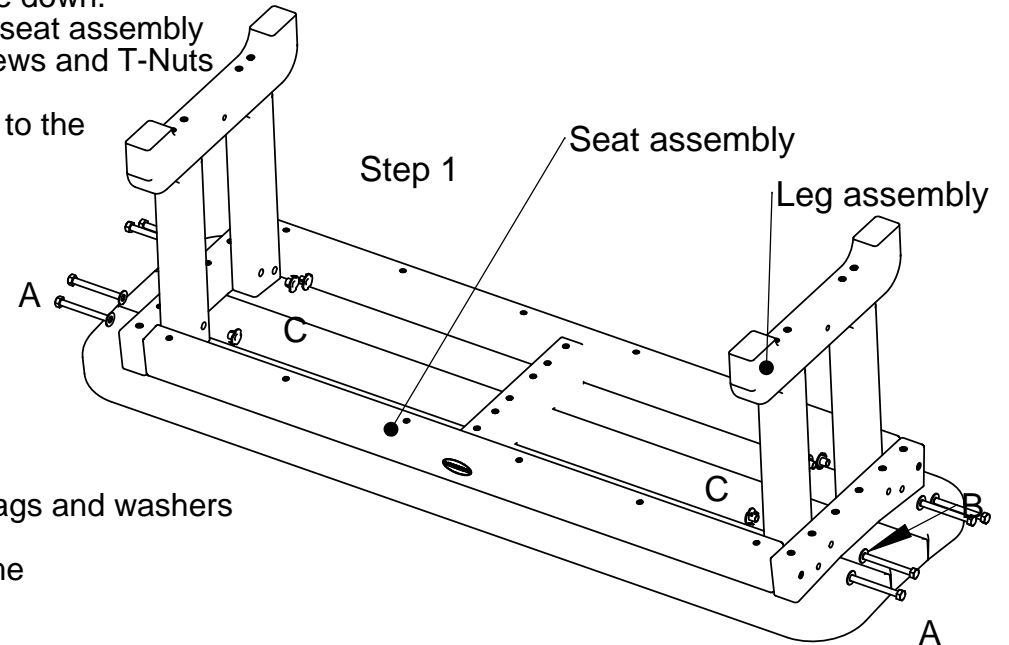

Step 2
Attach brace using (2) 3" lags and washers

*Tighten all bolts at this time

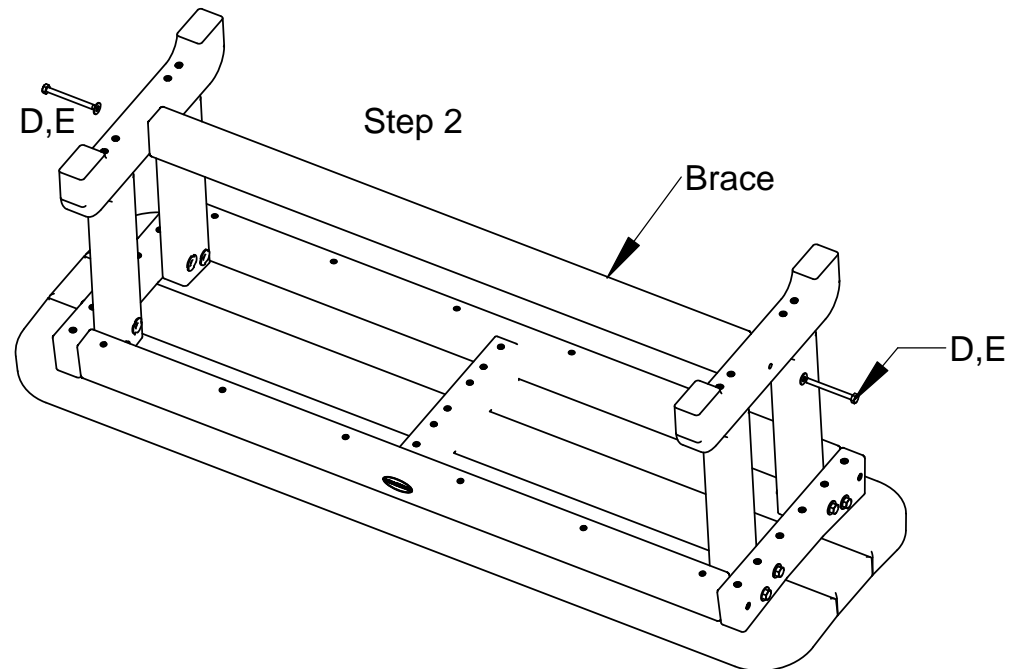

Qty.	Description
8	A-5/16-18 X 3 HEX CAP SCREW
8	B-5/16 X 3/4 OD FLAT WASHER
8	C-5/16-18 X 3/8 T-NUT 3 PRONG SS
2	D-1/4 X 3 HEX LAG SCREW
2	E-1/4 FLAT WASHER