

# POLYWOOD®

Intelligent Design™

MODEL: PB48

## TOOLS NEEDED

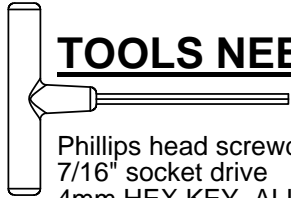

Phillips head screwdriver  
7/16" socket drive  
4mm HEX KEY, ALLEN, T-HANDLE  
(INCLUDED)

Qty.	Description
8	A - 1/4-20 X 3-1/4 WAFER SHCS
8	B - 5/16-18 X 3 HEX CAP SCREW
8	5/16 X 3/4 OD FLAT WASHER
8	5/16-18 X 3/8 T-NUT 3 PRONG SS
2	C - 1/4 X 3 HEX LAG SCREW
2	1/4 FLAT WASHER

Qty.	Description
8	A - 1/4-20 X 3-1/4 WAFER SHCS
8	B - 5/16-18 X 3 HEX CAP SCREW
8	5/16 X 3/4 OD FLAT WASHER
8	5/16-18 X 3/8 T-NUT 3 PRONG SS
2	C - 1/4 X 3 HEX LAG SCREW
2	1/4 FLAT WASHER

ASSEMBLY INSTRUCTIONS

### Step 1

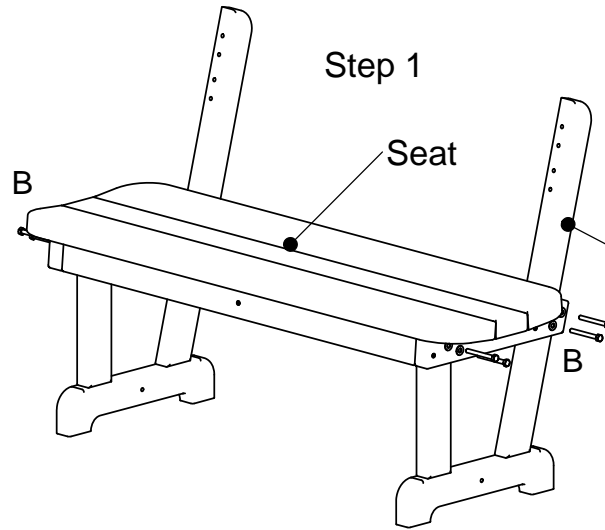

### Step 1

Attach T-NUT to inside of the leg assembly with a hammer

With the (8) hex bolts and washers attach side frames to seat

Note: Side frames attach to the inside of the seat frame.

Side frame

### Step 2

Attach brace to feet using (2) 3" lag bolts with washers

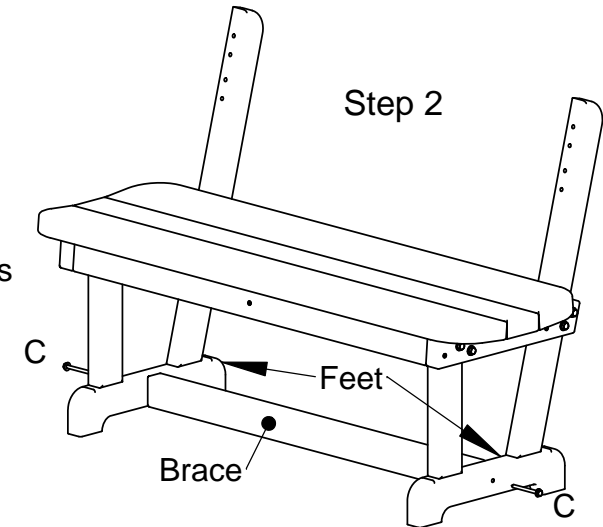

### Step 2

Brace

Feet

### Step 3

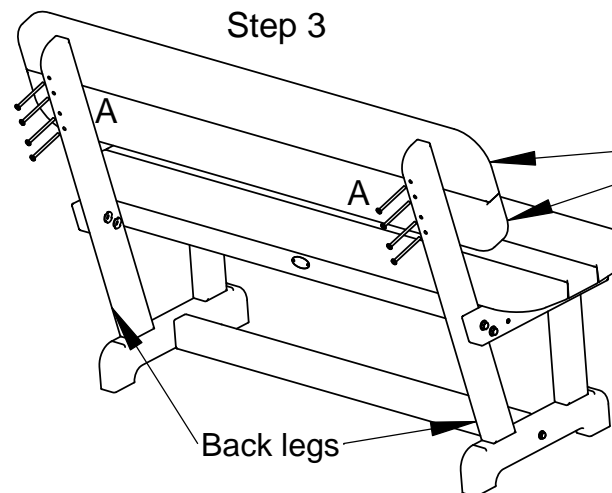

Back slats

Back legs

### Step 3

Attach back slats to back legs using (8) 3-1/4" bolts

\* Tighten all bolts at this time

ALL HARDWARE IS STAINLESS STEEL

11/29/2012