

Model:
NCT44, NCCT44,
NCRT44, NCBT44

- (1) Table top
- (4) Leg
- (2) Foot
- (2) Brace
- (1) Hardware pack

Step 1
Attach feet to legs using (4) 3/4" Chair bolts.

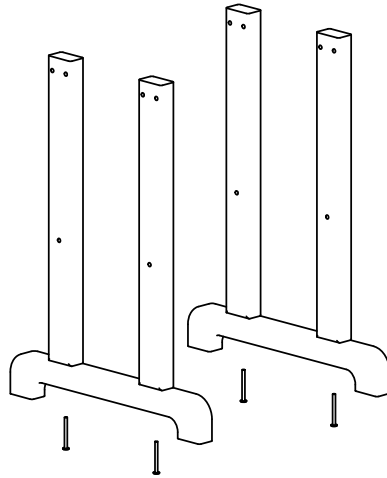

Step 2
Lay table top on flat surface.
Attach the leg assemblies to the table frame using
(8) .27x2 1/2" screw *Do not tighten until last step

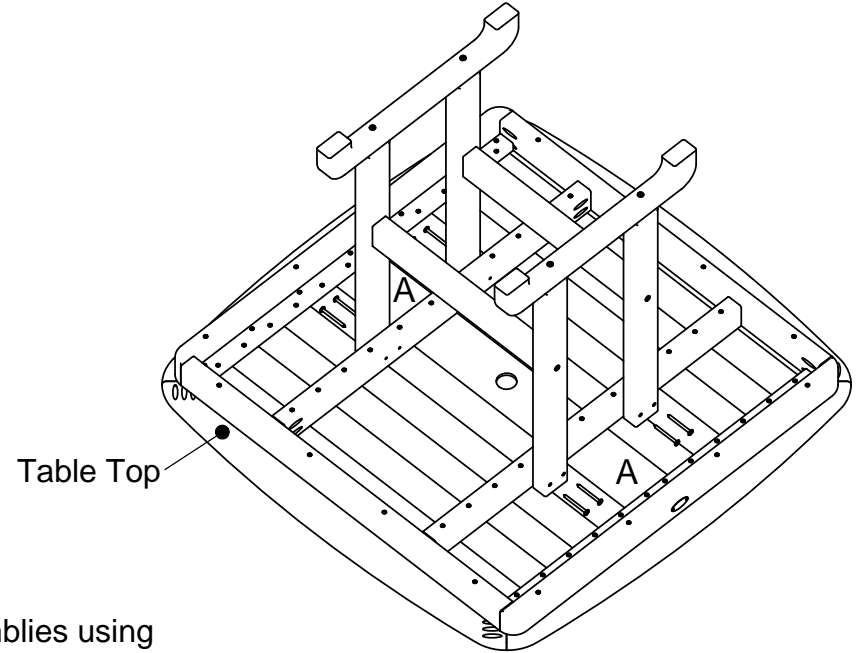

Step 3
Attach the leg braces to the leg assemblies using
(4) .27x3" screw

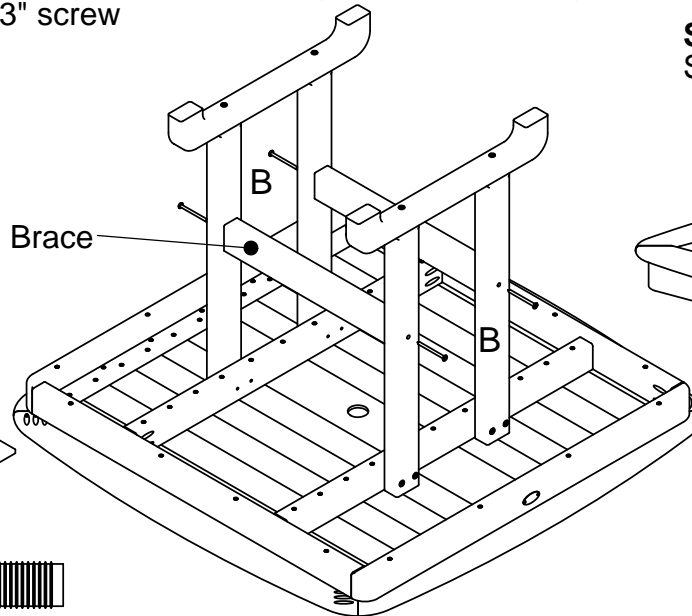

Step 4
Set table upright and tighten all bolts.
Removable table plug
included in table.

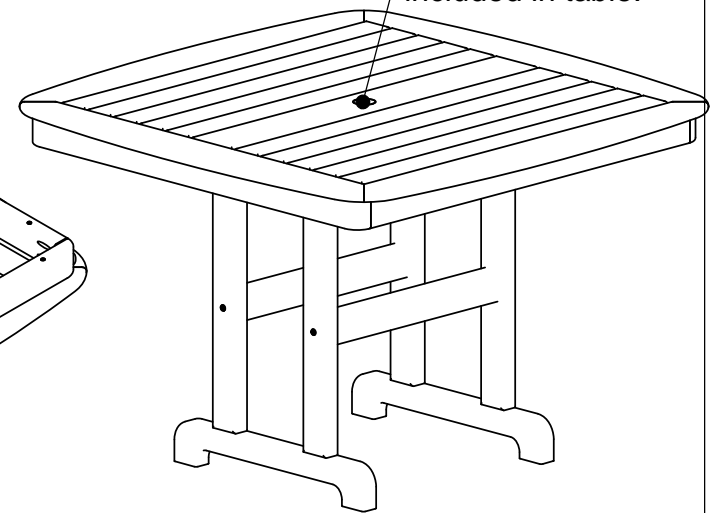

TOOLS NEEDED



4mm HEX KEY: INCLUDED

Qty.	Description
8	A - .27 X 2-1/2 SOCKET WAFER A
4	B - .27 X 3 SOCKET WAFER A
4	C - 1/4-20 X 3-1/4 WAFER SHCS