



Intelligent Design™

Model: NAC2280

- (2) Sideframe
- (1) Seat
- (1) Back
- (2) Stretcher
- (1) Stetcher assembly
- (2) Front leg
- (1) Metal brace
- (1) Hardware pack

**Step 1**  
Attatch front legs to seat assembly using (4) 1 3/4" bolts.

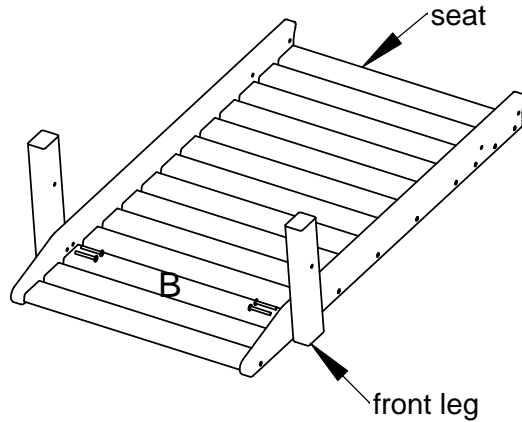

**Step 2**  
Attatch sideframes to the seat assembly and the back assebmly using (6) 1 3/4" bolts.

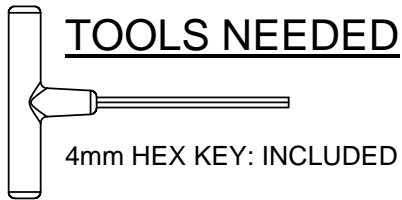
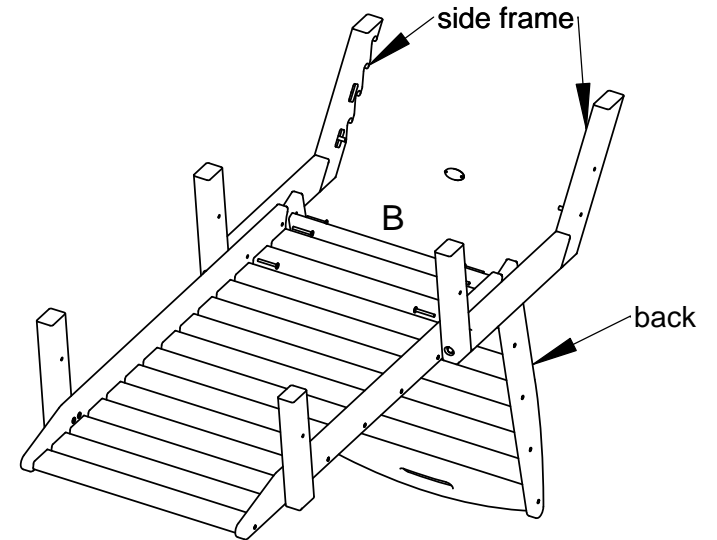

**Step 3**  
Attatch metal brace to the seat using (2) 1 1/2" bolts.

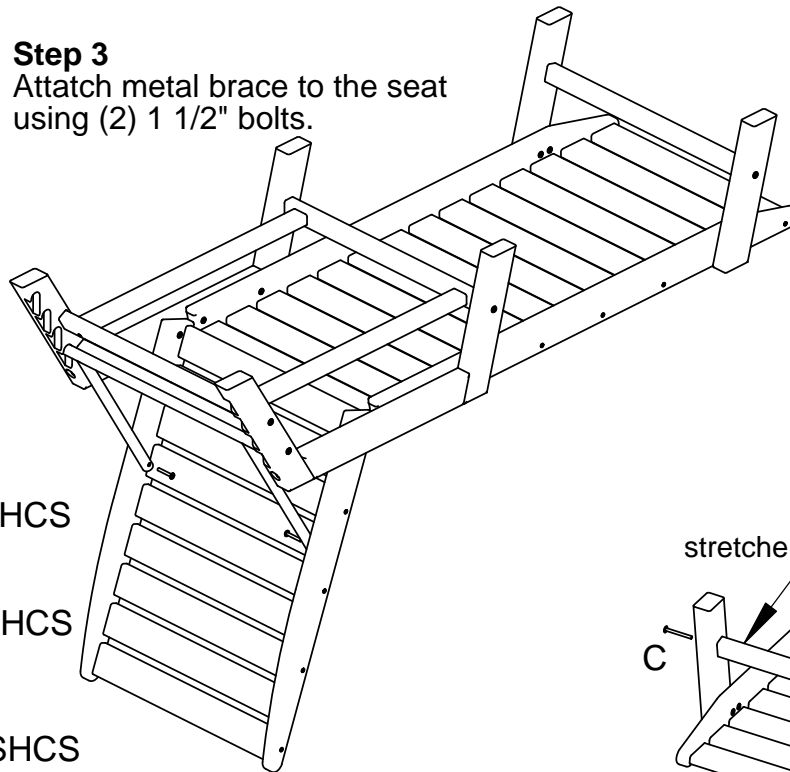

**Step 4**  
Attatch stretchers to the legs using (8) 2 1/4" bolts.

Note: Angle on stretcher assembly faces rear of chair.

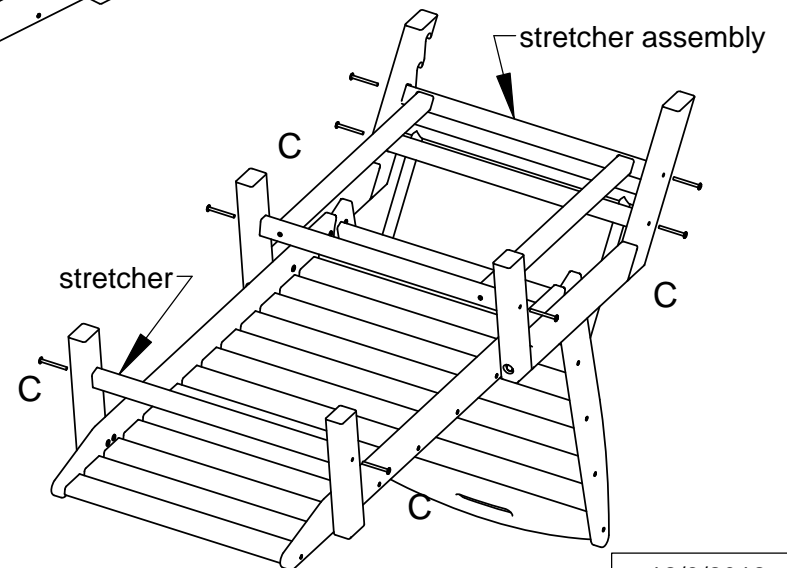

Qty.	Description
2	A-1/4-20 X 1-1/2 WAFER SHCS
10	B-1/4-20 X 1-3/4 WAFER SHCS
8	C-1/4-20 X 2-1/4 WAFER SHCS

- |    |                             |
|----|-----------------------------|
| 2  | A-1/4-20 X 1-1/2 WAFER SHCS |
| 10 | B-1/4-20 X 1-3/4 WAFER SHCS |
| 8  | C-1/4-20 X 2-1/4 WAFER SHCS |