

Model: GNB48, GNB481

- (1) Seat
- (1) Back
- (2) Sideframes
- (2) Angle braces
- (1) Hardware pack

TOOLS NEEDED

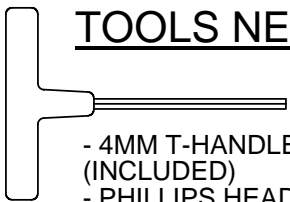

- 4MM T-HANDLE HEX KEY (INCLUDED)
- PHILLIPS HEAD SCREWDRIVER (SCREW GUN RECCOMENDED)

Step 1
Attach sideframes to seat using (6) 1 3/4" chair bolts

Do not tighten screws until last step.

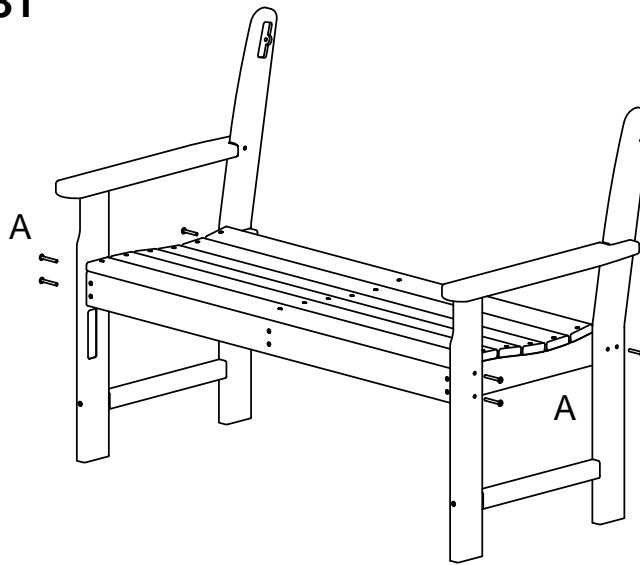

Step 2
- Attach back to seat using (2) 1 3/4" chair bolts
- Attach back to sideframes using (2) 2 1/2" chair bolts

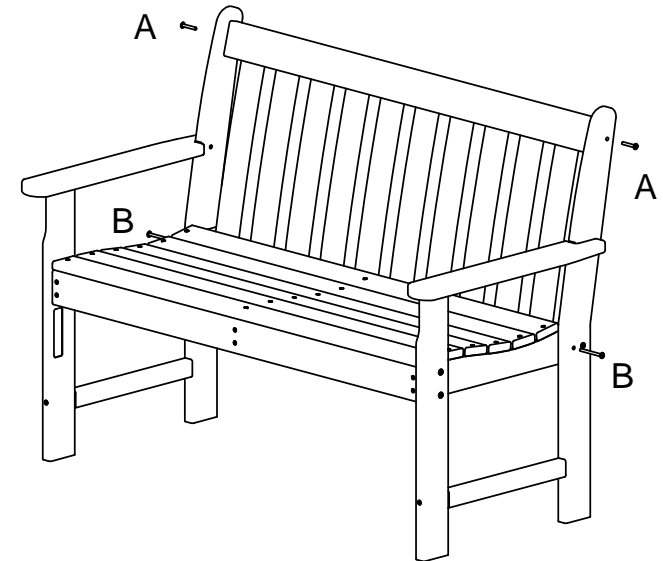

Step 3
Attach back to seat using (1) 1 3/4" chair bolts

Step 4
Attach angle brace to front leg then seat using (4) 8x2" screws

Tighten all screws.

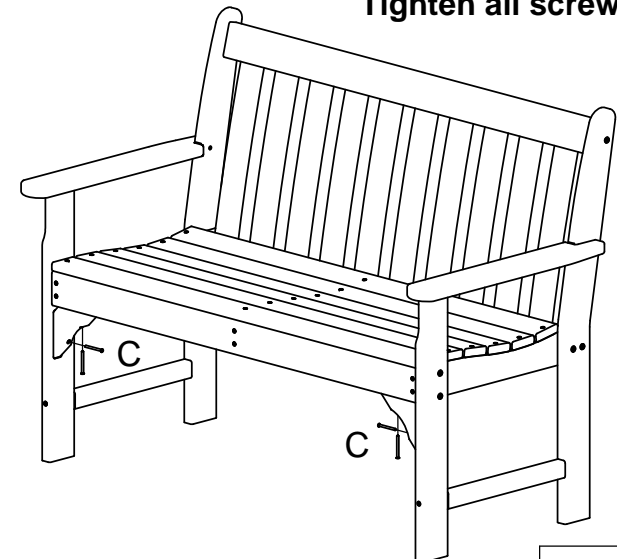
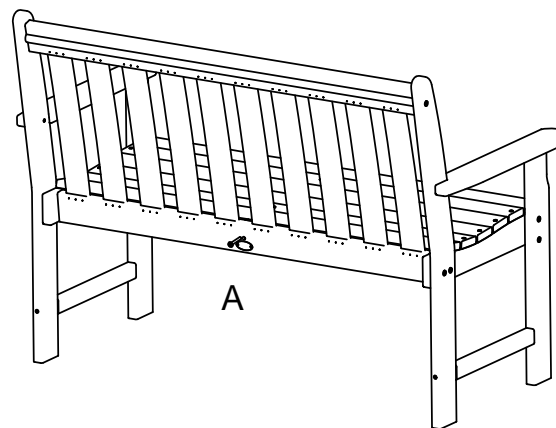

Qty.	Description
9	A - 1/4-20 X 1-3/4 WAFER SHCS
2	B - 1/4-20 X 2-1/2 WAFER SHCS
4	C - 8 X 2 PHIL FLAT SCREW