



Intelligent Design™

Model: ECR16

- (1) Seat
- (1) Back
- (2) Front legs
- (2) Back legs
- (2) Arms
- (2) Braces
- (2) Rockers
- (1) Hardware pack

TOOLS NEEDED



7/16 Wrench
4mm HEX KEY, ALLEN, T-HANDLE
(INCLUDED)

Step 1

Lay seat on its side. Attach front leg and back leg to seat. Now flip seat around and do the other side. Uses (6) 1-7/8" bolts, nuts and washer

Wings face forward

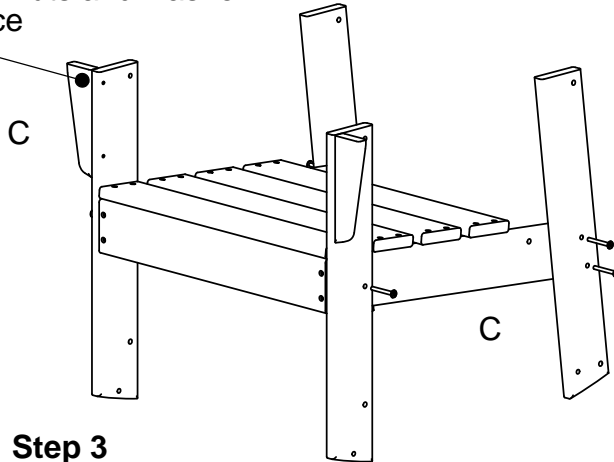

Step 2

Attach arms to front leg using (2) 2-1/4" bolts, nuts and washer

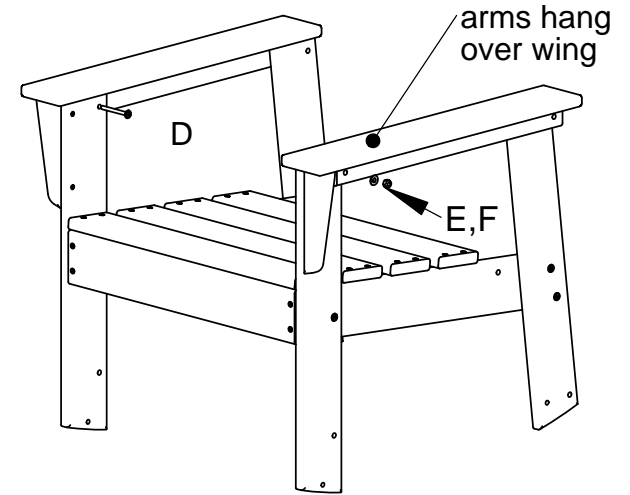

Step 3

Attach back to seat using (2) 2" screws

Attach back to rear leg using (2) 3" screws

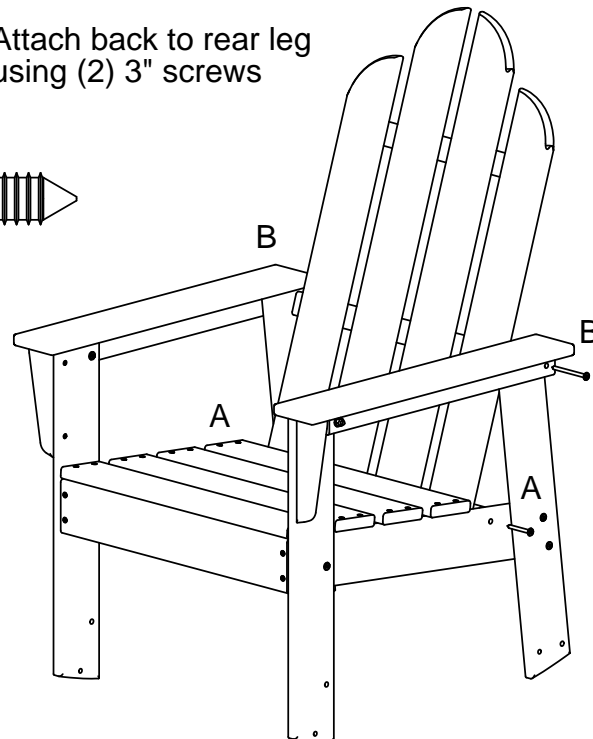

Step 4

Attach rockers to legs using (4) 1-7/8" bolts, nuts and washer

Attach brace to front leg using (2) 2" screws

Attach brace to rear leg using (2) 3" screws

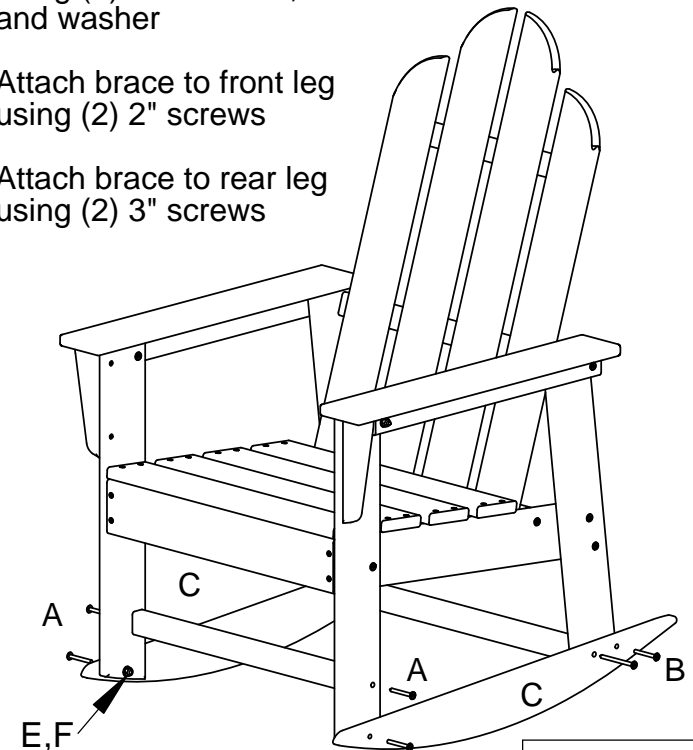

Qty. Description

4	A-.27 X 2 SOCKET WAFER A	
4	B-.27 X 3 SOCKET WAFER A	
10	C-1/4-20 X 1-7/8 WAFER SHCS	
2	D-1/4-20 X 2-1/4 WAFER SHCS	
12	E-1/4 FLAT WASHER	
12	F-1/4-20 NYLOCK NUT	