

# POLYWOOD®

Intelligent Design™

Model: ECC76

- (1) Seat
- (1) Back
- (2) Front legs
- (2) Back legs
- (2) Mid legs
- (2) Arms
- (3) Braces
- (1) Hardware pack

### Step 1

Lay seat on its side. Attach legs to seat. Now flip seat around and do the other side. Uses (16) 1-1/2 screws

### Step 2

Attach braces to legs using (6) 2" wafer screws

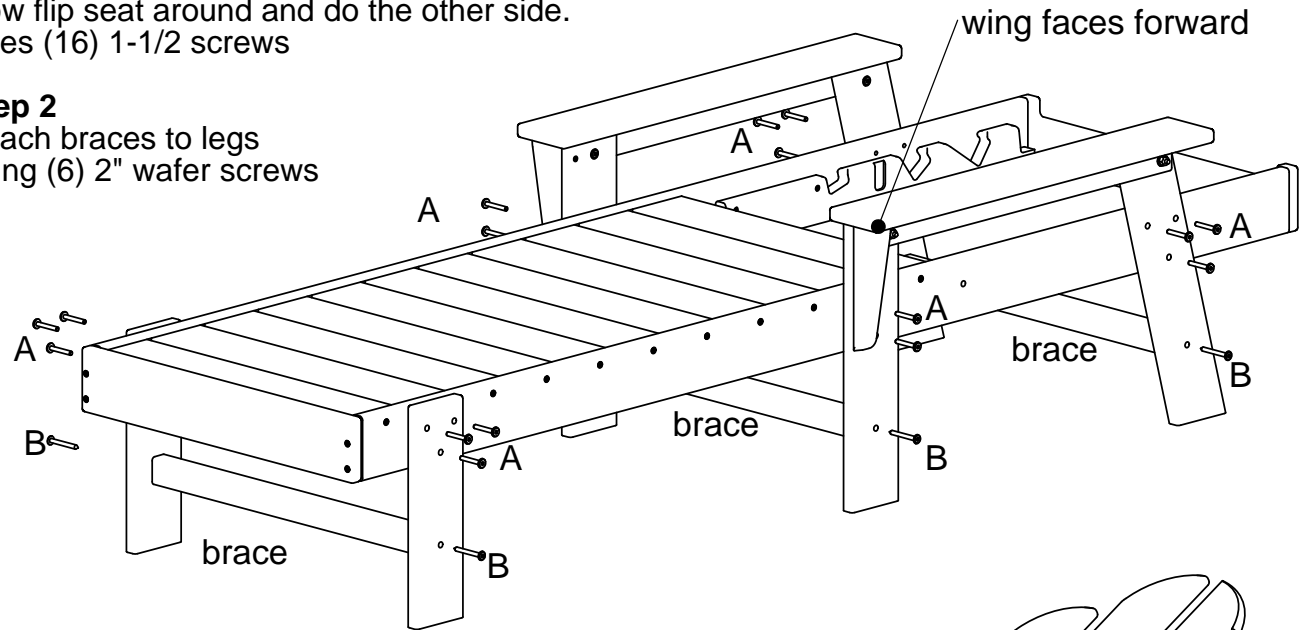

### Step 3

Attach arms to legs using (4) 2-1/4 bolts, nuts and washer

### Step 4

Attach back to seat using (2) 2" screws

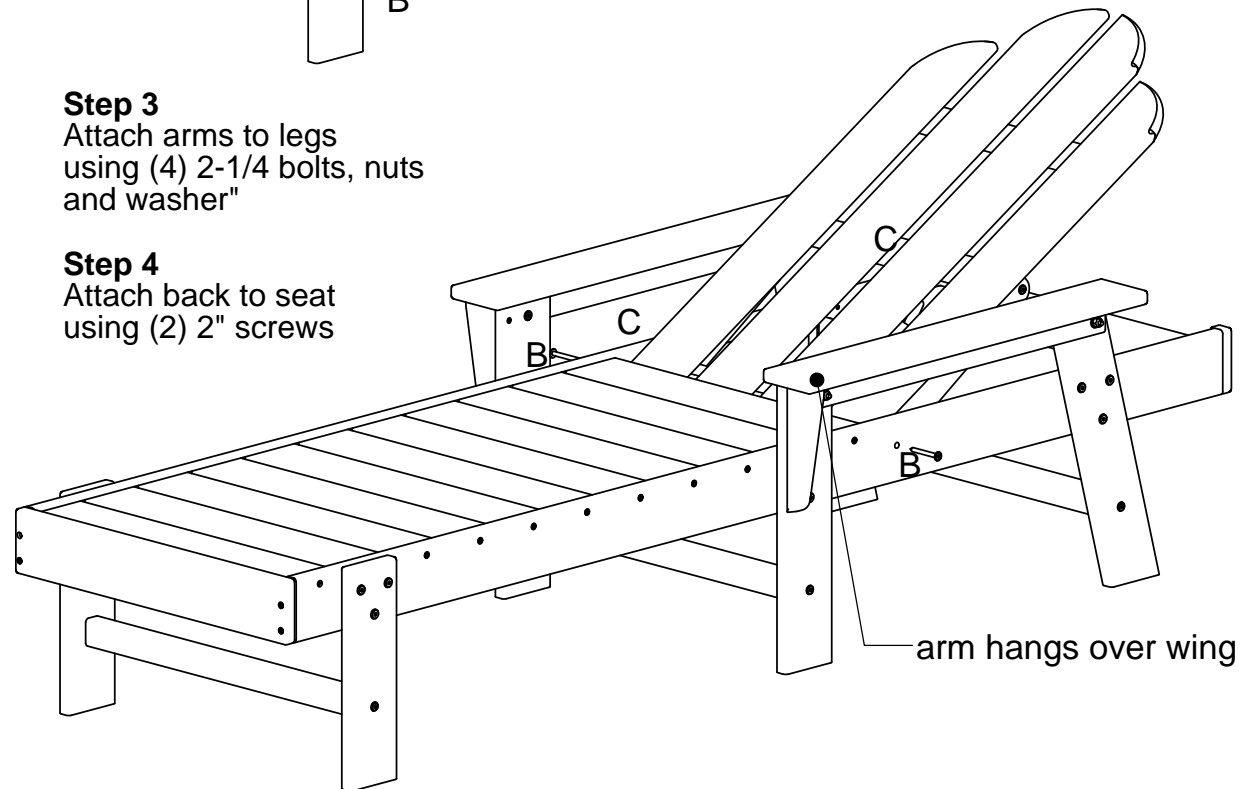

## TOOLS NEEDED



7/16 Wrench  
4mm Hex Key (included)

Qty.	Description
16	A-14 X 1-1/2 SOCKET WAFER "B"
8	B-.27 X 2 SOCKET WAFER A
4	C-1/4-20 X 2-1/4 WAFER SHCS
4	D-1/4 FLAT WASHER
4	E-1/4-20 NYLOCK NUT