



SEARING STATION BUILT-IN 3287-1(P)

INSTALLATION AND OPERATING INSTRUCTIONS

INSTALLER: Leave these instructions with consumer.
CONSUMER: Retain for future reference.



SAFETY WARNINGS & CODES

IMPORTANT: READ THESE INSTRUCTIONS CAREFULLY BEFORE STARTING INSTALLATION OR USE.

⚠ DANGER

IF YOU SMELL GAS:

1. Shut off the gas to the appliance.
2. Extinguish any open flame.
3. Open lid if equipped.
4. If odor continues, keep away from the appliance and immediately call your gas supplier or fire department.

⚠ WARNING

1. Do not store or use gasoline or other flammable vapors and liquids in the vicinity of this or any other appliance.
2. A propane cylinder not connected for use shall not be stored in the vicinity of this or any other appliance.

CODE AND SUPPLY REQUIREMENTS: This unit must be installed in accordance with local codes and ordinances, or, in the absence of local codes, with either the latest National Fuel Gas Code (ANSI Z223.1/NFPA 54), or Natural Gas and Propane Storage and Handling Installation Code (CSA-B149.1).

⚠ WARNING

Improper installation, adjustment, alteration, service, or maintenance can cause injury or property damage. Refer to this manual. For assistance or additional information, consult a qualified professional installer, service agency, or the gas supplier.

This appliance and its individual shutoff valves must be disconnected from the gas-supply piping system when testing the system at pressures in excess of 1/2 psig (3.5 kPa).

All electrical outlets in the vicinity of the unit must be properly grounded in accordance with local codes, or, in the absence of local codes, with the *National Electrical Code, ANSI/NFPA 70*, or the *Canadian Electrical Code, CSA C22.1*, whichever is applicable.

This appliance must be isolated from the gas-supply piping system by closing its individual manual shutoff valves during any pressure testing of the gas-supply system at pressures up to and including 1/2 psig (3.5 kPa).

Keep all electrical-supply cords and fuel-supply hoses away from any heated surface.

Certified to: ANSI Z21.58-2007
CSA 1.6-2007





BRÛLEUR DESSÉCHANT INCORPORÉ 3287-1(P)



INSTALLATION ET CONSIGNES D'UTILISATION

INSTALLATEUR : Laissez ces instructions avec le consommateur.

CONSUMMATEUR : Maintenez pour la future référence.

AVERTISSEMENTS ET CODES DE SÛRETÉ

IMPORTANT: LISEZ CES INSTRUCTIONS SOIGNEUSEMENT AVANT DE COMMENCER L'INSTALLATION

⚠ DANGER:

S'il y a une odeur de gaz:

1. Coupez l'admission de gaz de l'appareil.
2. Éteindre toute flamme nue.
3. Ouvrir le couvercle.
4. Si l'odeur persiste, gardez loin de l'appareil, et appelez immédiatement le fournisseur de gaz ou le service d'incendie.

⚠ AVERTISSEMENT:

1. Ne pas entreposer ni utiliser de l'essence ni d'autres vapeurs ou liquides inflammables dans le voisinage de l'appareil, ni de proximité de tout autre appareil.
2. Une bouteille de propane qui n'est pas raccordée en vue de son utilisation, ne doit pas être entreposée dans le voisinage de cet appareil ou de tout autre appareil.

CONDITIONS DE CODE ET D'APPROVISIONNEMENT: Ce grill doit être installé selon des codes et des ordonnances locaux, ou, en l'absence des codes locaux, avec l'un ou l'autre le plus défunt code national de gaz de carburant (norme ANSI Z223.1/NFPA 54), et stockage de gaz naturel et de propane et manipulation du code d'installation (CSA-B149.1).

Cet appareil et ses différents robinets d'isolement doivent être démontés du système sifflant d'offre de gaz en examinant le système aux pressions au-dessus du 1/2 psig (kPa 3.5).

Cet appareil doit être isolé dans le système sifflant d'offre de gaz par fermeture ses différents robinets d'isolement manuels pendant tous les essais sous pression du circuit

Certifié à la norme: ANSI Z21.58-2007
CSA 1.6-2007



AVERTISSEMENT

L'installation inexacte, l'ajustement, le changement, le service ou l'entretien peuvent causer des dommages ou des dégâts matériels. Référez-vous à ce manuel. Pour l'aide ou l'information additionnelle consultez un installateur

Toutes les sorties électriques à proximité du grill doivent être correctement fondues selon des codes locaux ou, en l'absence des codes locaux, avec le *code électrique national, ANSI/NFPA 70, ou le code électrique canadien, CSA C22.1*, qui est jamais applicable.

Gardez tout cordon d'alimentation électrique et tuyau d'alimentation en combustible à l'écart des surfaces chauffées.

TABLE OF CONTENTS

1	SAFETY WARNINGS & CODES
3	TABLE OF CONTENTS
3	CAUTION
3	PRODUCT DATA TABLE
4	PARTS LIST
5	PLANNING FOR INSTALLATION OF THE SEARING STATION
5	WHERE TO INSTALL THE SEARING STATION
5	ENSURING PROPER COMBUSTION AIR AND COOLING AIRFLOW
5	EXHAUST REMOVAL
6	INSTALLATION
6	GAS-SUPPLY PLUMBING REQUIREMENTS
6	CHECKING FUEL AND ORIFICES
7	CONVERTING THE REGULATOR
7	CONNECTING THE GAS SUPPLY
7	LEAK TESTING
8	NOTES PAGE
9	GENERAL INFORMATION
9	SAFETY TIPS IN USING THE SEARING STATION
9	CARE AND CLEANING
9	FLAME PATTERN
9	SEARING STATION FLAME PATTERN
11	SAFE USE & MAINTENANCE OF PROPANE GAS BOTTLES
13	LIGHTING (IGNITION) INSTRUCTIONS
13	SHUTTING OFF THE UNIT
14	WARRANTY

CAUTION

Do not strike or scrape the ceramic portion of the burner with hard tools, as the material may crack, chip, or break. Prevent any grease, water, or other foreign material from getting into the ceramic portion of the burner, especially when cold. Always wait for the burner to heat up to a well-distributed red glow before placing food on the cooking grid. When a burner is hot, it will vaporize small amounts of grease that drip on it. Always cover the burner when not in use. Keeping the ceramic portion of the burner free of foreign substances will allow the gas to circulate and burn over the entire heating surface, allowing for powerful and even cooking over the life of the burner.

PRODUCT DATA TABLE

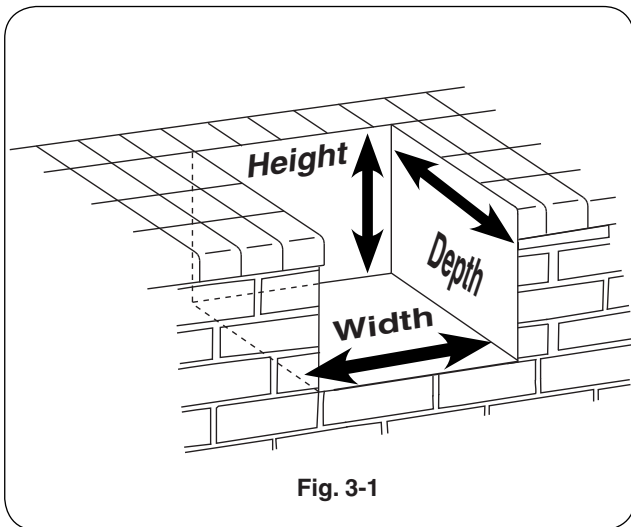

Fig. 3-1

Specification	Value
Counter opening height*	12"
Counter opening width*	14"
Counter opening depth*	22- ³ / ₄ "
Main burner	
BTU per burner	24,400
Natural-gas orifice	#45
Propane-gas orifice	#55

Table 1 - Product data table

***Note:** If using an insulating liner, consult liner instructions for counter cut-out dimensions.

PARTS LIST

Item	Description	Part No.	Qty.
1.	Cover	3287-07	1
2.	Stainless-steel grid	3551-S	1
3.	Burner assembly with ignitor	3049	1
4.	Stainless-steel control panel assembly	23287-05	1
5.	Valve manifold assembly	3287-22	1
6.	Control knob	3016	1
7.	Drip tray assembly with match holder	3085	1
8.	Regulator	PR-4	1
9.	Ignitor assembly	3199-35	1
10.	Infrared burner wire	3199-71	1
11.	Natural gas orifice ‡	3001-45-1	1
	or Propane gas orifice ‡	3001-55-1	1

‡ Not shown

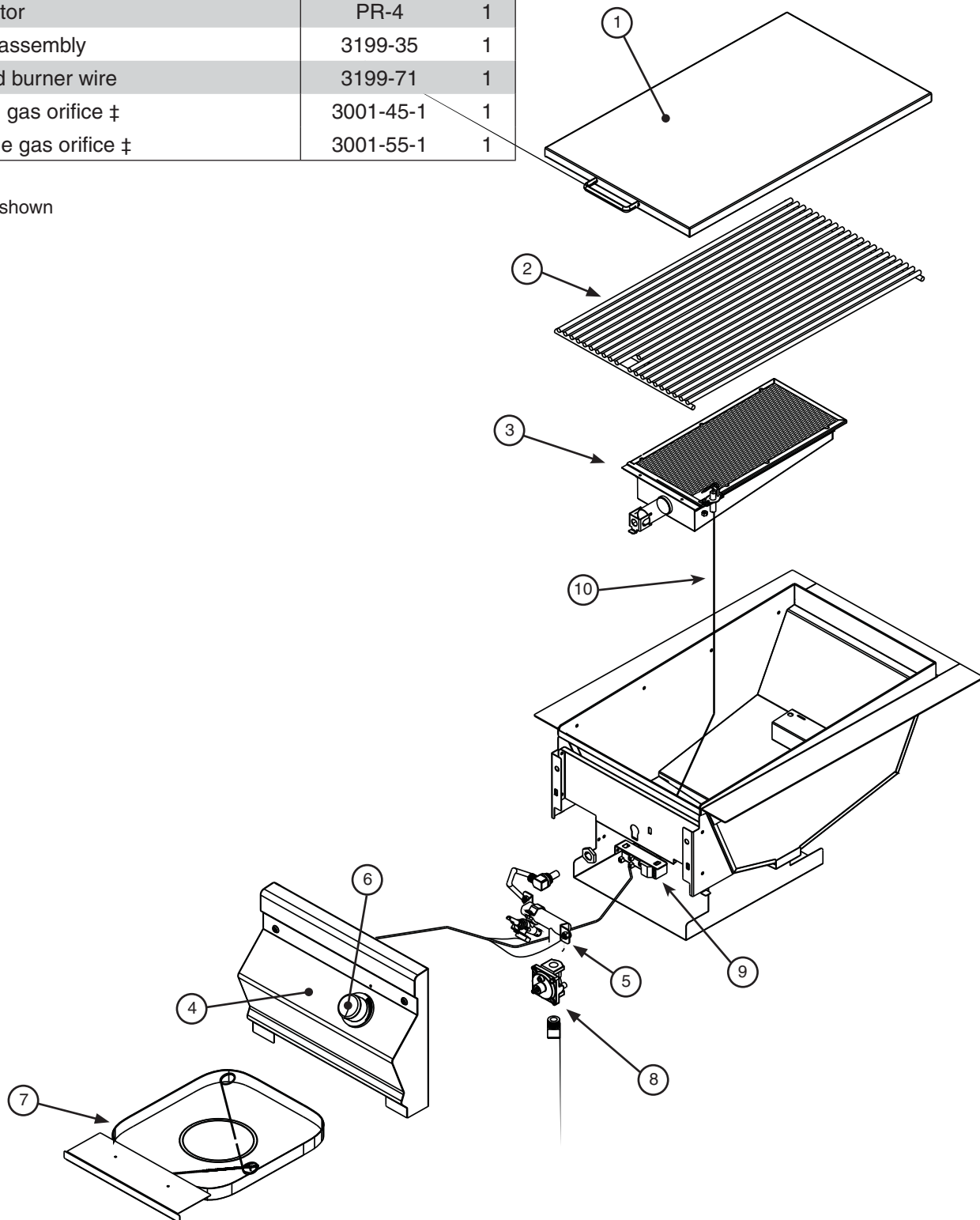

PLANNING FOR INSTALLATION OF THE SEARING STATION

WHERE TO INSTALL THE SEARING STATION

FOR OUTDOOR USE ONLY

WARNING: The unit must have a minimum of 18" right, left, and back clearance from unprotected combustible construction such as wood, plastic, or stucco with wood framing. If installing this unit in a combustible surround, the correct R.H. Peterson insulating liner must be used.

Do not install this unit under unprotected flammable surfaces. Do not install or use this appliance inside a building, garage, or any other covered or enclosed area. It must not be used in or on recreational vehicles or boats.

This is a built-in type unit designed to fit into open-front enclosures. The control panel of the unit is removable for gas hookup, servicing, and conversion. The control panel must remain removable after the unit is installed.

Installer Note: This unit should be installed so that it can be removed at a later date if factory service is required. Any protrusion into the searing station enclosure may prevent the unit from sliding into place (see GAS-SUPPLY PLUMBING REQUIREMENTS section).

ENSURING PROPER COMBUSTION AIR AND COOLING AIRFLOW

You must maintain proper airflow for the Fire-Magic® Searing Station to perform as it was designed (Fig. 5-1). If airflow is blocked, overheating and poor combustion will result. Make sure not to block the 1" front air inlet along the bottom of the control panel or more than 75% of the support grid surface with pans or griddles.

Note: The 1" front air space allows access to the drip tray.

EXHAUST REMOVAL

If installed under a patio roof, the cooking grid area should be fully covered by a chimney and exhaust hood.

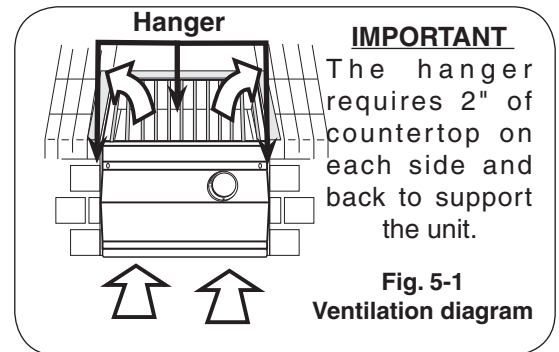

INSTALLATION

GAS-SUPPLY PLUMBING REQUIREMENTS

Rigid 1/2" black steel pipe is required to conduct the gas supply into the masonry opening for connection to the unit. Apply pipe joint compound (resistant to all gasses) to all male pipe fittings and tighten all joints securely. Do not use pipe joint compound to connect flare fittings. The pipe should enter the enclosure either from the bottom or from any side at least 13" below the countertop.

Note: Any protrusion into the enclosure higher than 13" below countertop will obstruct the frame and prevent the unit from dropping into place.

Note: An external valve (with a removable key) in the gas line is recommended for safety.

GAS-SUPPLY AND MANIFOLD PRESSURES

For natural gas: Normal 7" water column, minimum 5", maximum 10-1/2". For propane gas: Normal 11" water column, minimum 10", maximum 13". A REGULATOR MUST BE PROVIDED AT THE GAS SOURCE FOR USE WITH PROPANE GAS.

CHECKING FUEL AND ORIFICES

The Fire Magic® Sealing Station is equipped with orifices for natural gas unless otherwise indicated. For propane gas, smaller orifices must be installed to avoid hazardous overheating. (Please refer to Table 1 for the correct orifice size.) Check the orifice size by following the instructions below. The drill size is stamped on the orifice. If the number is not visible, you may have to remove the orifice (as detailed below) to read the number stamped on the side of the orifice.

When converting the unit, follow the steps below:

1. Remove the Sealing Station lid and lift off the cooking grid.
2. Remove the control knob and screws first, and then carefully lift away the control panel. This allows access to the regulator (see next page).

Important: Prior to fully removing the control panel, you must disconnect the battery holder assembly wires that are located behind the control panel.

3. Pull the wire from the bottom of the electrode attached to the burner (Fig. 6-1) and carefully lift the burner up, allowing the tabs to clear the slots in the rear burner rest. Pull the gas-supply tube away from the orifice (see Fig. 5-2) located inside the circular opening in the front firewall of the unit.
4. Using a 3/8" socket, remove the orifice from the orifice holder (see Fig. 6-3) and check the number stamped on the face.
5. If an orifice change is necessary, replace the orifice with the correct-sized one.
6. Replace the gas-supply tube over the orifice, aligning the burner into the rear burner rest. Re attach the electrode wire.

Note: The regulator and gas connection elbow are located behind the control panel. For conversion / gas hook up; see the CONVERTING THE REGULATOR and/or CONNECTING THE GAS SUPPLY sections before replacing the control panel.

7. Replace the control panel, being sure to reconnect the battery holder assembly wires. Replace the control knob, cooking grid and lid.

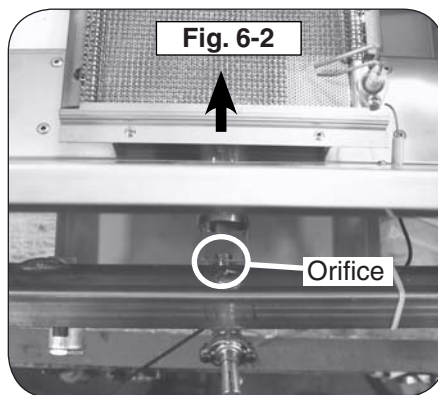
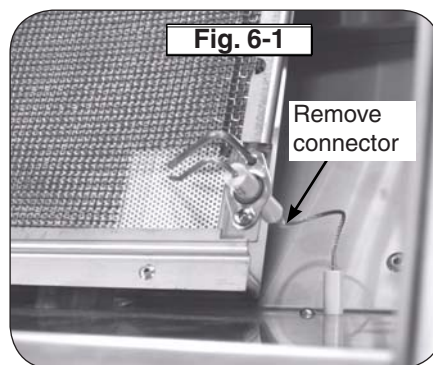

INSTALLATION (Cont.)

CONVERTING THE REGULATOR

1. Unscrew and remove the cap from the regulator, extracting the converter (Fig. 7-1).
2. Remove the converter (the plastic stalk) by carefully pulling it away from the center of the cap (it will snap out of its seating); see Fig. 7-2.
3. Turn the converter around and replace it carefully into the center of the cap (it will snap into place). Check that you can read (at the bottom of the stalk) the gas type the unit is set to use (Fig. 7-3).
4. Replace the unit into the regulator and screw down until snug. Do not over-tighten.

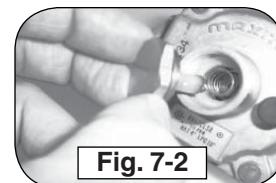
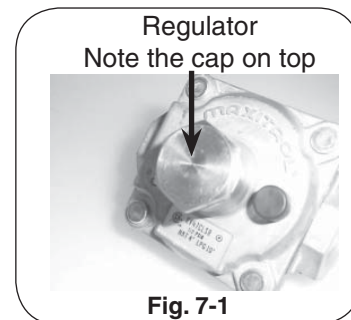

CONNECTING THE GAS SUPPLY

1. The burner manifold has a 1/2" male flare fitting gas inlet elbow. A 1/2" female flare fitting connector nut is required to hook the gas supply to the burner.
2. Use a stainless-steel flex connector to bring the gas supply from the gas-line stub or propane-gas tank to the Searing Station manifold. A 1/2" x 24" or 36" flex connector is suitable for most installations.

CAUTION: Use only a C.S.A.-listed stainless-steel flex connector. Do not use a rubber hose or plastic hose within the enclosure for the Searing Station; it will leak, resulting in an explosion and/or serious injury.

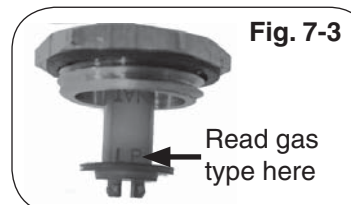

3. Be sure the gas supply is off. Connect the pipe adapter fitting supplied with the flex connector to the gas-supply stub. Use pipe joint compound that is resistant to all gasses on the pipe fitting. Tighten the fitting to the gas supply and connector flare nut securely.

Note: Pipe joint compound should not be used on flare fitting connections.

4. Connect the flex connector flare nut to the Searing Station manifold elbow flare fitting. Be sure to tighten securely. Use a second wrench to support the manifold to avoid damaging the manifold.
5. Slide the unit into the enclosure and replace the control panel.

LEAK TESTING

Carefully turn on the gas supply and leak test at all connections with a soapy water solution (equal parts liquid detergent and water). If bubbles appear, a leak is present. Turn off gas and tighten connections, turn

Please use this page to record any information about your unit that you may want to have at hand.

GENERAL INFORMATION

SAFETY TIPS IN USING THE SEARING STATION

Each time you use the Searing Station, ensure that:

1. The area around the unit is clear and free from flammable vapors, liquids, and other combustible materials.
2. There is no blockage of airflow around the burner.
3. When using propane gas, ensure that:
 - a. The special ventilation openings in the enclosure are kept free and clear of debris.
 - b. If connected to a propane cylinder, inspect the rubber hose attached to the regulator before each use.
 - c. Propane cylinder, regulator, and hose are installed in a location not subject to heating above 125°F (51° C).
4. Flame is burning evenly and steadily across the burner (mostly blue with yellow tipping).

Important: Do not operate the Searing Station with the cover closed.

CARE AND CLEANING

For cleaning purposes; always leave your burner on (after cooking) for an additional 5 minutes, to allow for a burnoff period. This is important to keep your burner clean and operating properly.

As the burner is self cleaning (at full temperature); avoid the use of cleaner or abrasives.

CAUTION: Never use acid chemicals or abrasive pads to clean porcelain or aluminum surfaces.

FLAME PATTERN

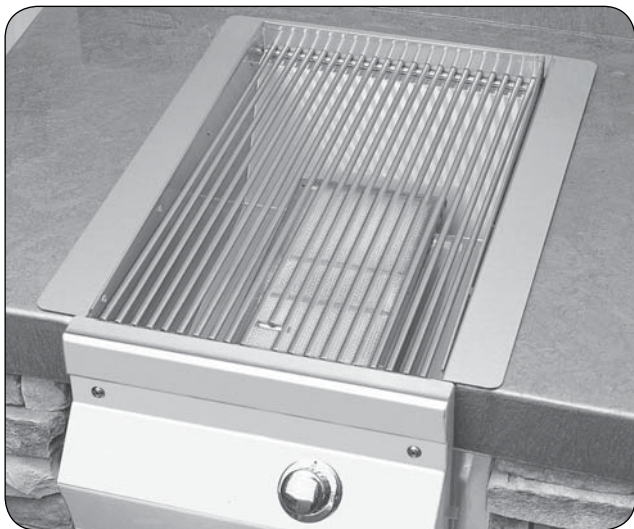

SEARING STATION FLAME PATTERN

A layer of flame may just be visible above the ceramic grid of the searing station burner especially around the edges. The flame will initially appear mostly blue with perhaps a few yellow flashes. Soon the red glow of the ceramic will be the primarily visible color of the burner top. Though there may be small areas of lesser or greater intensity, the overall red color will become fairly even after about three to five minutes.

UTILISATION SÛRE ET ENTRETIEN DES CYLINDRES DE GAZ DE PROPANE

IMPORTANT POUR VOTRE SÛRETÉ

LISEZ ET SUIVEZ TOUS LES AVERTISSEMENTS ÉQUIPÉS DE VOTRE CYLINDRE DE GAZ DE PROPANE.

En actionnant cet appareil avec un cylindre de gaz de propane ON DOIT observer ces instructions et avertissements.

LE MANQUE DE FAIRE AINSI PEUT AVOIR COMME CONSÉQUENCE UNE INCENDIE OU UNE EXPLOSION SÉRIEUSE.

CYLINDRE ET CONDITIONS ET

CARACTÉRISTIQUES DE CONNECTEUR

- Des cylindres et les valves de gaz de propane doivent être maintenus en bon état et doivent être remplacés s'il y a des dommages évidents au cylindre ou à la valve.
- Ce gril, une fois utilisé avec un cylindre, devrait être relié à un gallon de la norme 5 (20lb.) cylindre de gaz de propane équipé d'un OPD (remplissez au-dessus du niveau le dispositif d'empêchement). L'OPD a été exigé sur tous les cylindres vendus depuis octobre 1.1998 pour empêcher le remplissage excessif.
- Les dimensions de cylindre devraient être approximativement 12"(30.5cm) de diamètre et 18" (45.7cm) hauts. Des cylindres doivent être construits et marqués selon les caractéristiques pour des cylindres de gaz de propane du département des ETATS-UNIS du transport (D.O.T.) ou le niveau national du Canada, du CAN/CSA-B339, des cylindres, des sphères et des tubes pour le transport des marchandises dangereuses.
- Le cylindre doit inclure un collier pour protéger la valve de cylindre et le circuit d'alimentation de cylindre doit être assuré le retrait de vapeur.
- Le régulateur de pression et l'ensemble de tuyau utilisé doivent assortir les spécifications pour le type I par ANSI Z 21.58-2005/CGA 1.6-2005 (voir la fig. 10-1).

- La valve de cylindre de gaz de propane doit être équipée d'un dispositif d'accouplement de raccordement de cylindre, décrit comme type I dans la norme définie dans le e. de paragraphe ci-dessus. Ce dispositif est généralement décrit comme coupleur rapide de fil de point culminant.
- Si votre cylindre de gaz de propane vient avec une prise de la poussière, placez le bouchon anti-poussière sur la sortie de valve de cylindre toutes les fois que le cylindre n'est pas en service.

OPÉRATION DE COUPLEUR RAPIDE

Pour relier le régulateur/hose à l'ajustage de précision de valve de cylindre de gaz de propane: Serrez l'écrou de main sur le régulateur au-dessus de l'ajustage de précision de fil de point culminant sur la valve de cylindre. Tournez l'écrou de

main dans le sens des aiguilles d'une montre pour engager les fils et pour serrer jusqu'à ce que douillettement. L'utilisation des pinces ou de la clé ne devrait pas être nécessaire. Seulement le propane marqué par cylindres doit être employé.

Pour débrancher: Tournez l'écrou de main dans le sens contraire des aiguilles d'une montre jusqu'à isolé (fig. 10-1).

Important: Avant d'employer le gril, et ensuite chaque fois que le cylindre est enlevé et rattaché, examinez tous les raccordements pour déceler les fuites. Arrêtez les valves de gril et ouvrez la valve principale de cylindre, puis vérifiez les raccordements avec de l'eau savonneuse. Réparez toutes les fuites avant d'allumer le gril.

ATTENTION: Tournez toujours la valve principale de cylindre de propane au loin après chaque utilisation, et avant de déplacer le gril et le cylindre, ou débrancher l'accouplement. Cette valve doit rester fermée et le cylindre a débranché alors que l'appareil n'est pas en service, quoique l'écoulement de gaz soit arrêté par un dispositif de sûreté quand le coupleur est débranché.

Inspectez soigneusement l'ensemble de tuyau chaque fois avant que le gaz soit allumé. Un tuyau criqué ou frangé devrait être remplacé immédiatement.

Si l'appareil est stocké à l'intérieur, le cylindre doit être disconnected et a enlevé. Des cylindres Disconnected doivent être stockés dehors, hors de la portée des enfants, avec les prises de valve filettées étroitement installées, et ne doivent pas être stockés dans un bâtiment, le garage, ou n'importe quel autre secteur inclus.

POUR VOTRE SÛRETÉ

- Ne stockez pas un cylindre de gaz disponible de propane dessous ou ne vous approchez pas de cet appareil.
- Ne remplissez jamais cylindre au delà de 80 pour cent de plein.
- SI L'INFORMATION DANS "A" ET "B" N'EST PAS SUIVIE EXACTEMENT, UN FEU CAUSANT LA MORT OU DES DOMMAGES SÉRIEUX PEUT SE PRODUIRE.

Fig. 10-1 type coupleur rapide de fil de point culminant d'I

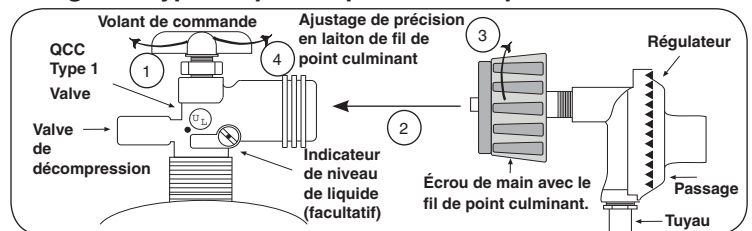

CONDITIONS DE CLÔTURE

POUR VOTRE SÉCURITÉ, vous devez fournir les ouvertures énumérées ci-dessous pour le drainage, l'air de remplacement, et une ventilation transversale d'une zone de stockage exposés à une fuite possible des raccordements de gaz, l'unité, ou de bouteilles de propane.

Un côté de l'enceinte peut être complètement ouvert sur l'extérieur, ou 4 ouvertures de ventilation doivent être créés:

Deux des ouvertures doivent être au niveau robinet de la bouteille (environ 16 "au-dessus du sol) et sur des parois opposées de l'enceinte. 2 ouvertures plus doit être au niveau du sol (env. 5 "au-dessus du sol) et sur les côtés opposés de l'enceinte. Chaque ouverture doit avoir un minimum de 10 pouces carrés de surface libre. Pour parvenir à la bonne ventilation, vous pouvez percer une série de trous, omettez le coulis de joints de maçonnerie, ou de remplacer une brique avec un écran de toile métallique. Si le plancher de l'armoire est soulevée et l'espace situé sous le caisson est ouvert vers l'extérieur, les ouvertures d'aération inférieures peuvent être dans le sol.

Consultez votre fournisseur de gaz pour les besoins de ventilation et de régulateur lors de la connexion à une alimentation en propane des ménages.

SAFE USE & MAINTENANCE OF PROPANE GAS CYLINDERS

IMPORTANT FOR YOUR SAFETY

READ AND FOLLOW ALL WARNINGS PROVIDED WITH THE PROPANE-GAS CYLINDER.

When operating this appliance with a propane-gas cylinder, these instructions and warnings **MUST** be observed.

FAILURE TO DO SO MAY RESULT IN A SERIOUS FIRE OR EXPLOSION.

CYLINDER/CONNECTOR REQUIREMENTS

- Propane-gas cylinders, valves, and hoses must be maintained in good condition and must be replaced if there is visible damage to either the cylinder or valve. If the hose is cut or shows excessive abrasion or wear, it must be replaced before using the gas appliance (see **e.**).
- This unit, when used with a cylinder, should be connected to a standard 5-gallon (20 lb.) propane-gas cylinder equipped with an OPD (Overfill Prevention Device). The OPD has been required on all cylinders sold since October 1, 1998, to prevent overfilling.
- Cylinder dimensions should be approximately 12" (30.5 cm) in diameter and 18" (45.7 cm) high. Cylinders must be constructed and marked in accordance with the *Specifications for Propane Gas Cylinders of the U.S. Department of Transportation (D.O.T.)* or the National Standard of Canada, *CAN/CSA-B339, Cylinders, Spheres, and Tubes for Transportation of Dangerous Goods*.
- The cylinder used must include a collar to protect the cylinder valve, and the cylinder supply system must be arranged for vapor withdrawal.
- The pressure regulator and hose assembly used must match the specification for Type I by *ANSI Z 21.58-2005/CGA 1.6-2005* (see Fig. 11-1).
- The propane-gas cylinder valve must be equipped with a cylinder connection coupling device, described as Type I in the standard defined in paragraph **e.** above. This device is commonly described as an Acme thread quick coupler.
- If the propane-gas cylinder comes with a dust plug, place the dust cap on the cylinder valve outlet whenever the cylinder is not in use.

QUICK COUPLER OPERATION

To connect the regulator/hose assembly to the propane-gas cylinder valve fitting: Press the hand nut on the regulator over the Acme thread fitting on the cylinder valve. Turn the hand nut clockwise to engage the threads and tighten until snug.

ENCLOSURE REQUIREMENTS

FOR YOUR SAFETY, you must provide the openings listed below for drainage, replacement air, and cross-ventilation of any storage area exposed to possible leakage from gas connections, the unit, or propane cylinders.

One side of the enclosure can be left completely open to the outside, OR 4 ventilation openings must be created:

Two of the openings are to be at the cylinder valve level (approx. 16" above the floor) and on opposite walls of the enclosure. 2 more openings must be at the floor level (approx. 5" above the floor) and on opposite sides of the enclosure. Each opening must have a minimum of 10 sq. in. of free area. To achieve the proper ventilation, you may drill a series of holes, omit the grout from masonry joints, or replace a brick with a hardware cloth screen. If the floor in the cabinet is raised and the space beneath the cabinet is open to the outside, the lower ventilation openings may be in the floor.

Consult your gas supplier for ventilation and regulator requirements when connecting to a household propane supply.

The use of pliers or a wrench should not be necessary. Only cylinders marked "propane" may be used.

To disconnect: Turn the hand nut counterclockwise until detached (Fig. 11-1).

Important: Before using the unit, and after each time the cylinder is removed and reattached, check the hose for wear (see **a.**) and check all connections for leaks. Turn off the unit valves and open the main cylinder valve, then check connections with soapy water. Repair any leaks before lighting the unit.

CAUTION: Always turn the propane cylinder main valve off after each use, and before moving the unit and cylinder or disconnecting the coupling. This valve must remain closed and the cylinder disconnected while the appliance is not in use, even though the gas flow is stopped by a safety feature when the coupler is disconnected.

Carefully inspect the hose assembly each time before the gas is turned on. A cracked or frayed hose should be replaced immediately.

If the appliance is stored indoors, the cylinder must be disconnected and removed. Disconnected cylinders must be stored outdoors, out of the reach of children, with threaded valve plugs tightly installed, and must not be stored in a building, garage, or any other enclosed area.

FOR YOUR SAFETY

- DO NOT store a spare propane-gas cylinder under or near this appliance.
- NEVER fill the cylinder beyond 80-percent full.
- IF THE INFORMATION IN **a.** AND **b.** IS NOT FOLLOWED EXACTLY, A FIRE CAUSING DEATH OR SERIOUS INJURY MAY OCCUR.

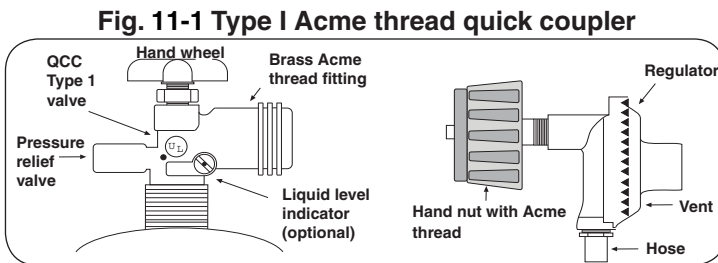

ALLUMAGE DES INSTRUCTIONS (D'ALLUMAGE)

Lisez toutes les instructions avant l'allumage, et suivez ces instructions chaque fois vous lumière le unité.

ÉCLAIRAGE ÉLECTRONIQUE

Note: L'éclairage électronique exige une batterie installée de 9 volts avec une bonne charge.

1. Ouvrez les couvercles ou enlevez les couvertures des brûleurs pour être Lit.
2. Tournez tous les boutons de commande de gaz à leurs positions de repos.
3. Allumez le gaz à sa source.

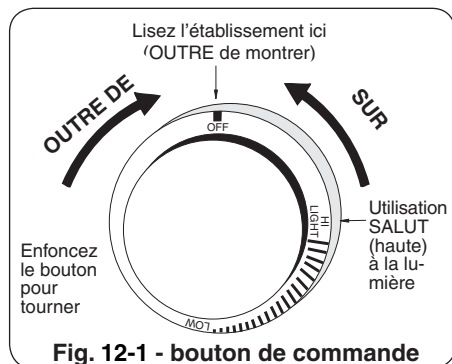

4. Diminuez le bouton de commande désiré pendant 5 secondes, puis, et tout en pressant le tour il dans le sens contraire des aiguilles d'une montre dans la position LÉGÈRE de HI. Une fois que le brûleur s'allume, libérez le bouton.

ATTENTION : Si un brûleur ne s'allume pas dans cinq (5) secondes d'allumer le bouton de commande, enfoncez le bouton et tournez-le à la position de repos. ATTENDEZ CINQ (5) MINUTES avant de répéter l'étape 4. Si vous sentez le gaz, suivez les instructions sur la couverture de ce manuel. Si les brûleurs ne s'allument toujours pas après que plusieurs tentatives, se rapportent aux instructions pour l'éclairage manuel.

REMPACEMENT DES BATTERIES D'ALLUMEUR

Pour remplacer la batterie de 9V actionnant les allumeurs, retirez le support de batterie situé sur l'extérieur du panneau de commande. Enlevez le couvercle. Démontez la batterie du connecteur et remplacez-la reliant la nouvelle batterie. Remplacez le couvercle et fermez le tiroir (voir la fig. le 12- 3).

EN EMPLOYANT UN RÉSERVOIR DE PROPANE PORTATIF

Des réservoirs de propane sont équipés d'un dispositif d'arrêt de sûreté qui peut ne pas causer le bas ou aucunes pression de gaz/flamme aux brûleurs si le fonctionnement et l'allumage des instructions ne sont pas suivis exactement (voir la note importante dans la section de dépannage pour plus de détails.)

ÉCLAIRAGE MANUEL

ATTENTION: Attendez toujours cinq (5) minutes le gaz pour se dégager après que n'importe quelle tentative non réussie d'éclairage.

1. Suivez les étapes 1 à 3 (à gauche).
2. Insérez un allumeur brûlant de butane de long-baril, une allumette brûlante de long-tige, ou une allumette brûlante tenue par un support de prolongation de fil par la grille à cuire s'ouvrant au dessus du brûleur (fig. 12-2).
3. Tout en tenant l'allumette ou la flamme plus légère au dessus du brûleur, diminuez le bouton de commande et tout en pressant le tour il dans le sens contraire des aiguilles d'une montre dans la position LÉGÈRE de HI. Enlevez l'allumeur ou assortissez quand le brûleur s'allume, et libérez le bouton de commande.
4. Si le brûleur ne s'allume pas, enfoncez immédiatement le bouton et tournez la valve à AU LOIN. ATTENDEZ CINQ (5) MINUTES avant de répéter les étapes 2 à 4 des instructions manuelles d'éclairage.

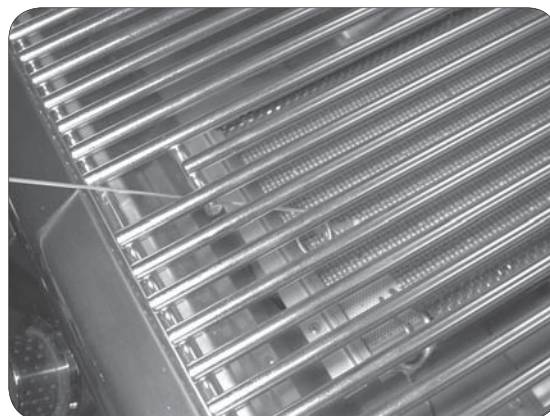

Fig. 12-2 - Éclairage manuel

ARRÊT DU UNITÉ

Pour couper le unité, diminuez chaque bouton de commande de valve et, et tout en pressant tour il dans le sens des aiguilles d'une montre à la position de repos.

Fermez toujours la valve de la fourniture de gaz après chaque utilisation du unité.



LIGHTING (IGNITION) INSTRUCTIONS

Read all instructions before lighting, and follow these instructions each time you light the unit.

ELECTRONIC LIGHTING

Note: Electronic lighting requires an installed 9-volt battery with a good charge.

1. Open lid(s) or remove cover(s) from burner(s) to be lit.
2. Turn all gas control knob(s) to their **OFF** position(s).
3. Turn on the gas at its source.

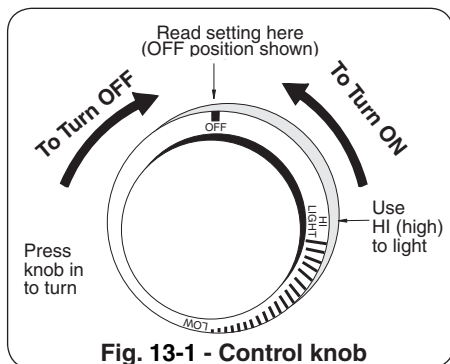

4. Depress the desired control knob **for 5 seconds**, then, while pressing turn it counterclockwise to the **HI LIGHT** position. Once the burner lights, release the knob.

CAUTION: If a burner does not light within five (5) *seconds* of turning on the control knob, depress the knob and turn it to the **OFF** position. **WAIT FIVE (5) MINUTES** before repeating step 4. If you smell gas, follow the instructions on the cover of this manual. If the burners still do not light after several attempts, refer to the instructions for manual lighting.

REPLACING IGNITOR BATTERIES

To replace the 9V battery powering the ignitors, pull out the battery holder located on the outside of the control panel. Remove the lid. Disconnect the battery from the connector and replace it connecting the new battery. Replace the lid and close the drawer (see Fig. 13-3).

WHEN USING A PORTABLE PROPANE TANK

Propane tanks are equipped with a safety shutdown device that may cause low or no gas pressure/flame at the burners if operating and lighting instructions are not followed exactly (See important note in the TROUBLESHOOTING section for more details.)

MANUAL LIGHTING

CAUTION: Always wait five (5) minutes for gas to clear after any unsuccessful lighting attempt.

1. Follow steps 1 through 3 (left).
2. Insert either a burning long-barrel butane lighter, a burning long-stem match, or a burning match held by a wire extension holder through the cooking grid opening to the top of the burner (Fig. 13-2).
3. While holding the match or lighter flame at the top of the burner, depress the control knob and while pressing turn it counterclockwise to the **HI LIGHT** position. Remove the lighter or match when the burner lights, and release the control knob.
4. If the burner does not light, **immediately depress the knob and turn the valve to OFF**. **WAIT FIVE (5) MINUTES** before repeating steps 2 through 4 of the **MANUAL LIGHTING** instructions.

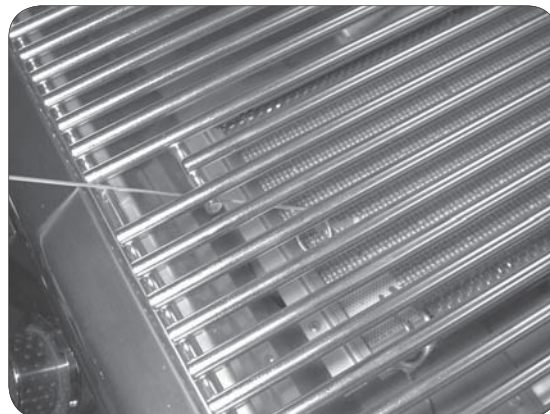

Fig. 13-2 - Manual lighting

SHUTTING OFF THE UNIT

To shut off the unit, depress each valve control knob and, while pressing turn it clockwise to the **OFF** position.

Always close the valve from the gas supply after each use of the unit.



WARRANTY

PETERSON FIRE MAGIC GRILLS AND ACCESSORIES LIMITED WARRANTY

Robert H. Peterson Co. ("RHP") warrants your Fire Magic® grill to be free from defects in material and workmanship.

Fire Magic® cast stainless-steel burners, stainless-steel rod cooking grids, and stainless-steel housings are warranted for as long as you own your Fire Magic® grill -- **LIFETIME**. (Except as noted below.)

Fire Magic Choice stainless steel tubular burners are warranted for **TWENTY (20) YEARS**.

Fire Magic® cast brass burners, brass valves, inner liners, manifold assemblies, and backburner assemblies (except ignition parts) are warranted for **FIFTEEN (15) YEARS**.

Fire Magic® Electric Grills, including stainless steel grid, and housings are warranted for **TEN (10) YEARS**.

Fire Magic® Infra-red burners, flavor grids, Charcoal stainless steel grills, and Smokers are warranted for **FIVE (5) YEARS**; except for the charcoal pan, charcoal grid, wood pellet screen, thermometer, and ash tray; which are warranted for **ONE (1) YEAR**.

Fire Magic® sideburners and all other Fire Magic® grill components (except ignition and electronic parts) are warranted for **THREE (3) YEARS**.

Fire Magic® ignition systems (excluding batteries), electronic components (including lights and thermometers), and grill accessories are warranted for **ONE (1) YEAR**.

A COPY OF YOUR SALES SLIP FOR PROOF OF PURCHASE IS REQUIRED

This warranty applies to the original purchaser for products which are installed in the United States or Canada and which are operated and maintained as intended for single family residential usage. This warranty is valid only with proof of purchase, shall commence on the date of purchase, and shall terminate (both as to original and any replacement products) on the anniversary date of the original purchase of the product stated on the above schedules.

This warranty covers defects in material and workmanship. This warranty **does not** cover parts which become defective as a result of negligence, misuse, use not in compliance with the Owner's Manual/Installation Instructions, accidental damage, improper handling, improper storage, improper installation, lack of required routine maintenance (as specified in the Owner's Manual/Installation Instructions), electrical damage, local gas impurities or failure to protect against combustibles. Product must be installed (and gas must be connected) as specified in the Owner's Manual/Installation Instructions by a **qualified professional installer**. Modifications to products which are not specifically authorized will void this warranty. Accessories, parts, valves, remotes, etc. when used must be Peterson products or this warranty is void. Warrantied items will be repaired or replaced at Peterson's sole discretion. This warranty **does not** apply to rust, corrosion, oxidation, or discoloration unless the affected part becomes inoperable.

This warranty **does not** cover labor or labor related charges, except as provided by separate specific written programs from the Peterson Co. All repair work must be performed by a qualified professional service person and requires prior approval of Peterson.

Peterson may require the defective product or part to be returned to the factory to determine the cause of failure. Peterson will pay freight charges if the product or part is determined to be defective. This warranty does not cover breakage in shipment from our (Independent) distributor to its customer if the damage is determined to have occurred during that shipment.

This warranty specifically excludes liability for **indirect, incidental, or consequential** damages. Some states and provinces do not allow the exclusion or limitation of incidental or consequential damages, so the above exclusion may not apply to you. This warranty gives you specified legal rights, and you may have other rights that vary from state to state or province.

For additional information regarding this warranty, or to place a warranty claim, contact the R. H. Peterson dealer where the product was purchased.

**TO REGISTER YOUR PRODUCT ONLINE GO TO: WWW.RHPETERSON.COM,
AND CLICK ON PRODUCT REGISTRATION. THANK YOU FOR YOUR PURCHASE.**

Quality Check			Date: _____	
Burner Orifices	Nat.	L.P.	Leak Test: _____	Model#: _____
Main:	_____	_____	Burn Test: _____	Serial#: _____
Other:	_____	_____	Gas Type: <u>Nat. / L.P.</u>	Air Shutter: _____
				Inspector: _____