



30" MASONRY GOURMET DRAWER



33830-S shown

INSTALLATION INSTRUCTIONS

- OUTSIDE DOOR MODELS:** #23830-S
#33830-S
#43830-S
- FLUSH DOOR MODELS:** #53830-S

SAFETY INFORMATION

WARNING
This unit is to be installed by a qualified, professional installer, or technician.

- GENERAL INFORMATION**
- When installing this unit directly below another unit, only install with Fire Magic built-in products.
 - Not following these instructions exactly will void the manufacturer's warranty.

Important: READ THESE INSTRUCTIONS CAREFULLY BEFORE STARTING INSTALLATION.

INSTALLER: Leave these instructions with consumer.
CONSUMER: Retain for future reference.

INSTALLATION

Before installing your Fire Magic® drawer, remove the drawer by completely pulling it out. Release the drawer from the drawer slides by pressing the black lever down on the right side, and up on the left side (Fig 2-1). Then pull outward on the drawer until it comes free of the runners.

For proper installation, be sure to use the correct cutout dimensions as specified for your specific model number (see table below).

1. In order to properly support the weight of your drawer, it is necessary to provide a secure, level surface in the rear of the unit. (See SIDE VIEW drawing below.) This may be accomplished by using bricks, 2 X 4's, etc. Be sure that the height of this rear support is $\frac{1}{8}$ " higher than that of the front opening support, so that your drawer sits level.

Note: It is recommended that silicon caulking (not supplied) is applied around the back of the drawer cabinet trim before sliding the cabinet assembly into the opening.

2. Slide in and fasten the unit securely into the masonry using lag bolts (not supplied) through the installation screw slots in the top and bottom of the unit (see drawings below).
3. To re-attach the drawer; extend the drawer slides completely and align the drawer into the slides, pushing the drawer closed. Open the drawer to verify that it has locked in place.

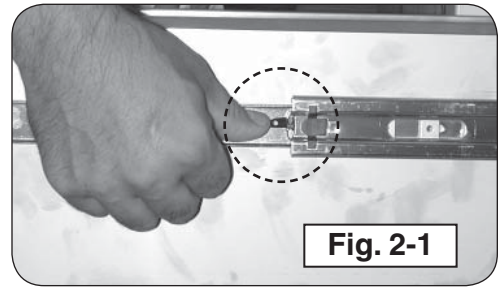
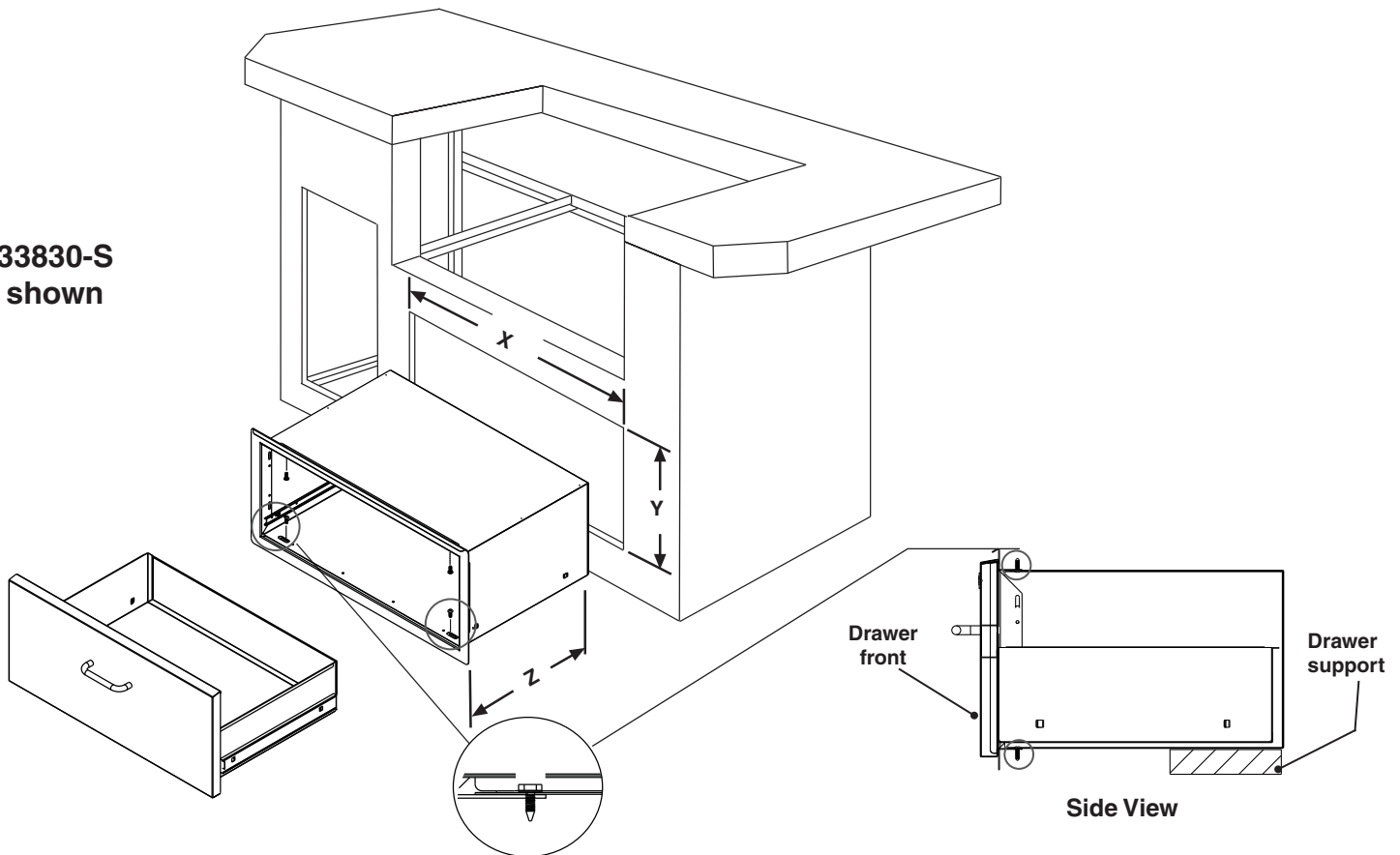

Fig. 2-1

CUTOUT DIMENSION			
Model #	X	Y	Z
23830-S	31"	13"	20 1/2"
33830-S	31"	13"	20 1/2"
43830-S	31"	13"	20 1/2"
53830-S	32 1/4"	14 1/2"	22"

**33830-S
shown**



CARE AND MAINTENANCE

The following care instructions will keep your unit looking and working like new. Meticulous attention has been given to maintain the attractive finish throughout the manufacturing process. Like the stainless steel used in commercial kitchens, your drawer requires regular cleaning and occasional buffing to maintain its bright, clean appearance (the inner drawer is removable for easy cleaning). Clean your drawer by first using Fire Magic Barbecue and Grill Cleaner (part #3580-1) to remove grease and dirt. Always wipe with the grain (See Fig. 3-2). Next, use Fire Magic Stainless Steel Cleaner (3581-1) to restore the stainless steel color. Finish by wiping your drawer down using Fire Magic Polish Wipes (3586-1).

Clean your drawer at least once a month.

If your drawer is installed in a seaside (salt air) or poolside (chlorine) location, it will be more susceptible to corrosion and must be maintained/cleaned more frequently. Do not store chemicals (such as chlorine or fertilizer) near your stainless steel drawer.

Due to the nature of stainless steel, surface iron oxide deposits may appear. Do not be alarmed – these deposits are removable with stainless-steel cleaner through prompt and periodic maintenance. If not attended to promptly, permanent pitting may occur.

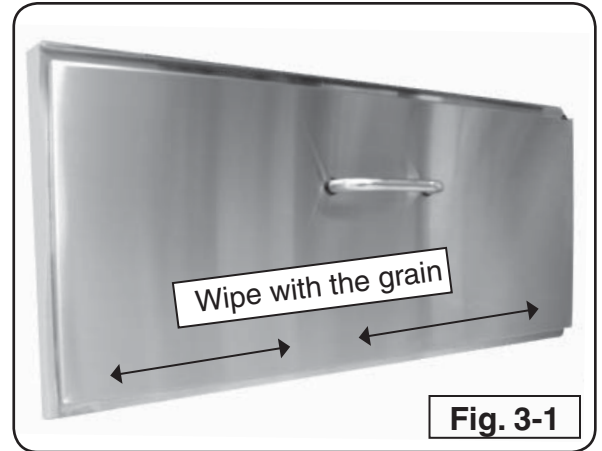

Fig. 3-1

WARRANTY

LIFETIME WARRANTY - Fire Magic® cast stainless-steel burners, stainless-steel rod cooking grids, and stainless-steel housings are warranted for as long as you own your Fire Magic® grill.

FIFTEEN-YEAR WARRANTY - Fire Magic® cast brass burners, brass valves, backburner assemblies (except ignition parts), and manifold assemblies are warranted for 15 years from the date of purchase of your Fire Magic® grill.

THREE-YEAR WARRANTY - Fire Magic® sideburners and all other Fire Magic® grill components (except ignition and electronic parts) are warranted for three (3) years from the date of purchase of your Fire Magic® grill.

Fire Magic® ignition systems (excluding batteries), electronic components (including lights and thermometers), and accessories are warranted for one (1) year from date of purchase.

PLEASE KEEP A COPY OF YOUR SALES SLIP FOR PROOF OF PURCHASE

This warranty applies to the original purchaser and to single family residential use only. It commences from date of purchase, and is valid only with proof of purchase.

This warranty does not cover parts becoming defective through misuse, accidental damage, electrical damage, improper handling, storage, and/or installation. Product must be installed (and gas must be connected) as specified in the instructions or operator's manual, by a **qualified professional installer**. Accessories, parts, valves, remotes, etc., when used must be Peterson Co. product.

This warranty **does not** apply to rust, corrosion, oxidation, or discoloration, unless the affected component becomes inoperable. It **does not** cover labor or labor-related charges.

This warranty specifically excludes liability for **indirect, incidental**, or consequential damages. Some states do not allow the exclusion or limitation of incidental or consequential damages, so the above exclusion may not apply to you. This warranty gives you specified legal rights, and you may have other rights that may vary from state to state.

For additional information regarding this warranty, or to place a warranty claim, contact the R.H. Peterson dealer where the product was purchased.

**TO REGISTER YOUR PRODUCT ONLINE GO TO: WWW.RHPETERSON.COM,
AND CLICK ON PRODUCT REGISTRATION. THANK YOU FOR YOUR PURCHASE.**