

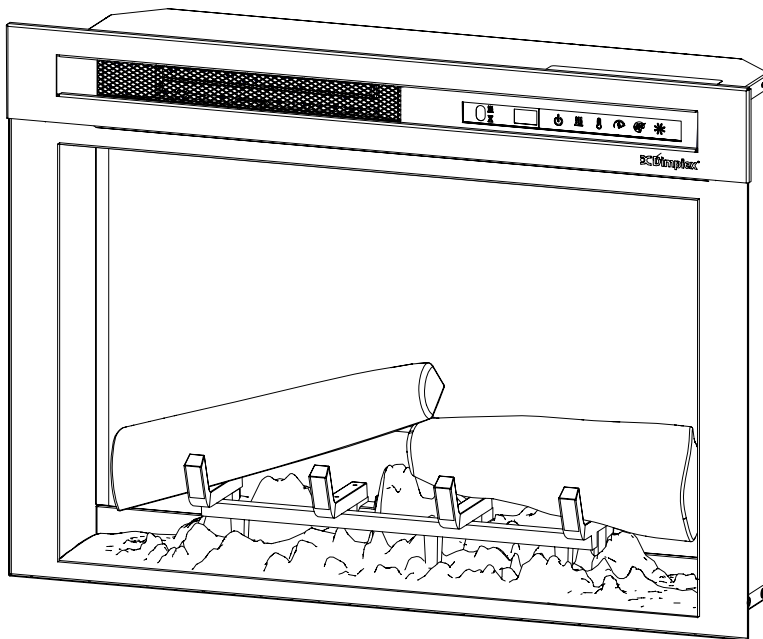

Service Manual



Models

XHD23L/XHD23G
XHD26L/XHD26G
XHD28L/XHD28G
XHD33L/XHD33G

DF26L-PRO
DF26DWC-PRO
DF28L-PRO
DF28DWC-PRO

Part Number

6909940XXX
6913820XXX
6909850XXX
6913830XXX
6909970XXX
6913840XXX
6913820XXX
6913830XXX
6913840XXX
6910090XXX

IMPORTANT SAFETY INFORMATION: Always read this manual first before attempting to service this firebox. For your safety, always comply with all warnings and safety instructions contained in this manual to prevent personal injury or property damage.

Table of Contents

XHD Replacement Parts List 1	3
XHD Replacement Parts List 2	4
DF-PRO Replacement Parts List	5
Wiring Diagrams	6
Accessing Top Components	7
Accessing Bottom components.	7
Power Cord Replacement.	8
Main Control Board Replacement	8
Heater Assembly Replacement	9
Touchpad Replacement	9
Flicker Motor Replacement.	10
Flicker Rod Replacement	10
Flame Base LED Strip Replacement	11
Media Tray / Media LED Strip Replacement	11
Flame Screen Replacement	12
Log Set Replacement	12
Troubleshooting Guide	13

Always use a qualified technician or service agency to repair this firebox.

! NOTE: Procedures and techniques that are considered important enough to emphasize.

⚠ CAUTION: Procedures and techniques which, if not carefully followed, will result in damage to the equipment.

⚠ WARNING: Procedures and techniques which, if not carefully followed, will expose the user to the risk of fire, serious injury, or death.

Exploded Parts Diagram

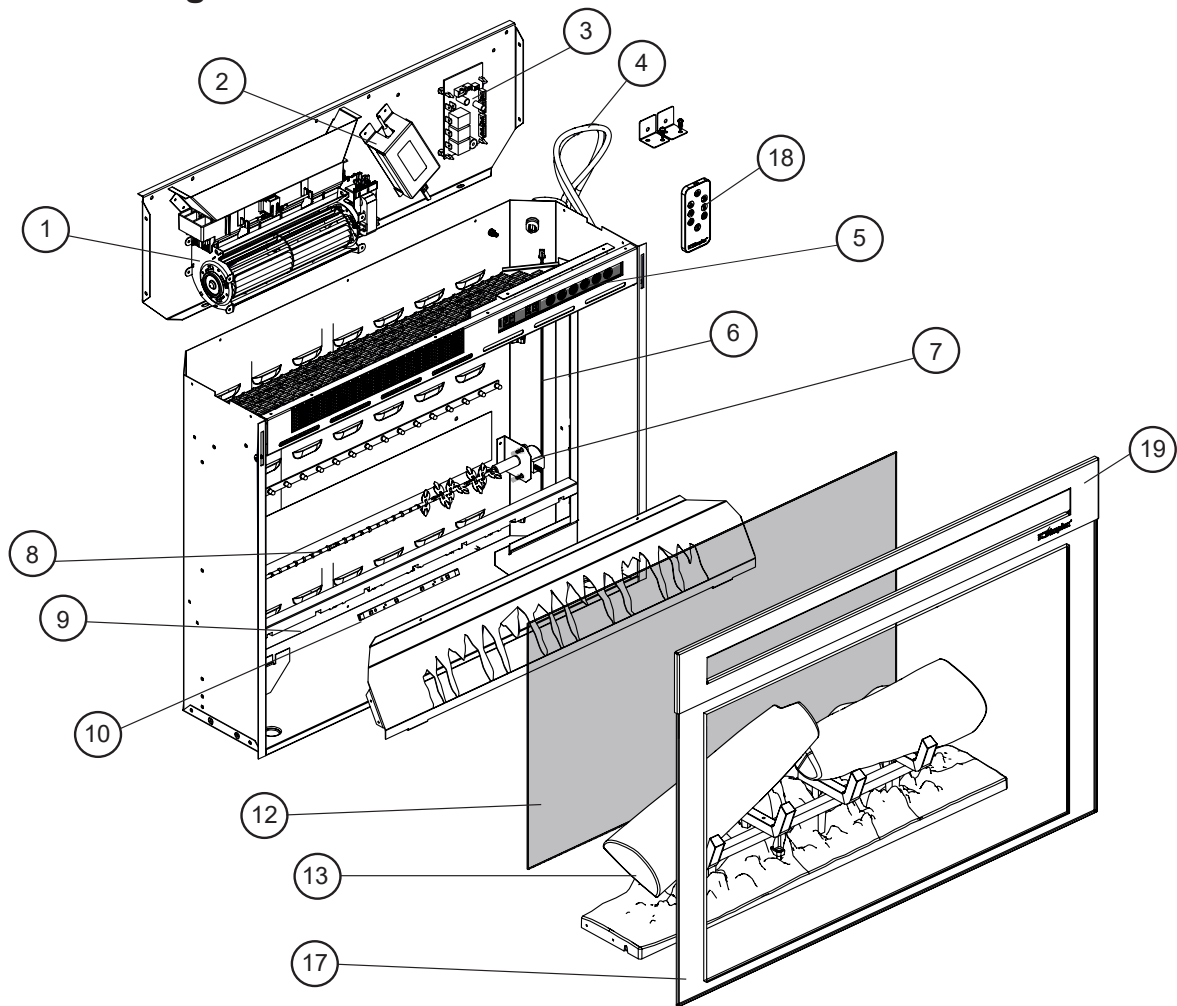

Replacement Parts List

XHD23 MOD 0-A
 XHD26 MOD 0-B
 XHD28 MOD 0-A

1. Heater Assembly	X-2203730300RP	12. Flame Screen XHD23	X-5902580400RP
2. Power Supply	X-2100250700RP	XHD26	X-5902580500RP
3. Main Control Board Logs	X-3001840100RP	XHD28	X-5902580600RP
Media	X-3001840200RP	13. Logset XHD23L	X-0442330100RP
4. Power Cord	X-4100190600RP	XHD26L	X-0442220100RP
5. Touchpad	X-6700600100RP	XHD28L	X-0442300100RP
6. Thermistor	X-3001560900RP	14. Media Tray XHD23G	X-0442320100RP
7. Flicker Motor	X-3000240200KIT	XHD26G	X-0442280100RP
8. Flicker Rod XHD23	X-5903090200RP	XHD28G	X-0442310100RP
XHD26 & XHD28	X-5903090100RP	15. Medium Ice Chunks (Media Models)	X-1400150100RP
9. Flame LED Strip XHD23	X-3002200100RP	16. Large Ice Chunks (Media Models)	X-1400130400RP
XHD26 & XHD28	X-3002200200RP	17. Front Glass XHD23	X-5903150100RP
10. Flame Base LEDs XHD23L & XHD26L	X-3001880100RP	XHD26	X-5903070100RP
XHD28L	X-3001880200RP	XHD28	X-5903160100RP
11. Media LED Strip XHD23G	X-3001570100RP	18. Remote Control	X-6700590200RP
XHD26G	X-3001570700RP	19. Mounting Hardware (XHD26)	X-9602100100RP
XHD28G	X-3001570300RP	20. Felt Feet Pads	X-8600140101RP

Exploded Parts Diagram

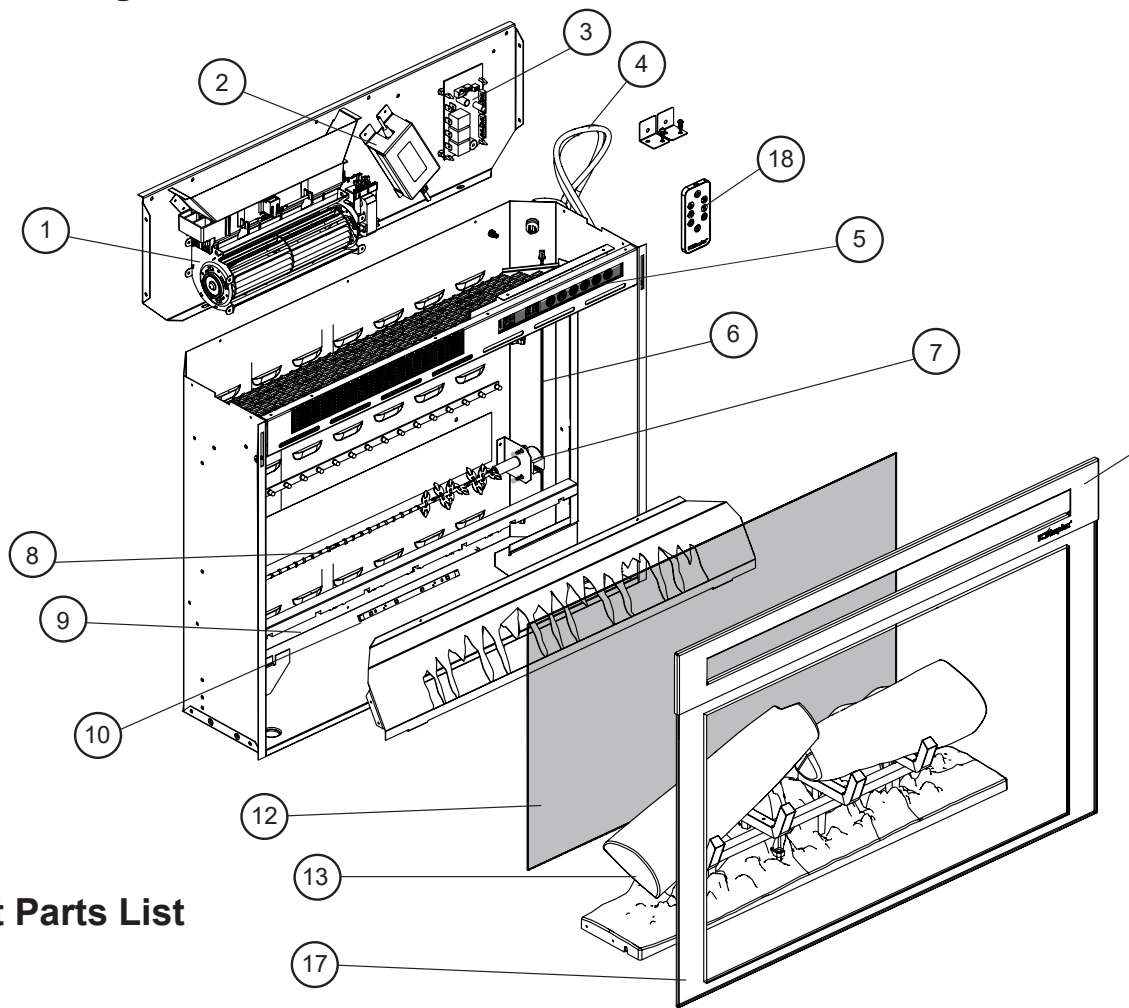

Replacement Parts List

XHD23 MOD B+
 XHD26 MOD C+
 XHD28 MOD B+
 XHD33 ALL MODS

1. Heater Assembly	X-2203610700RP	12. Flame Screen XHD23	X-5902580400RP
2. Power Supply	X-2100250700RP	XHD26	X-5902580500RP
3. Main Control Board Logs Media	X-3001840100RP X-3001840200RP	XHD28	X-5902580600RP
4. Power Cord	X-4100190700RP	XHD33	500001936
5. Touchpad	X-6700600100RP	13. Logset XHD23L	X-0442330100RP
6. Thermistor	X-3001560800RP	XHD26L	X-0442220100RP
7. Flicker Motor	X-3000240200KIT	XHD28L	X-0442300100RP
8. Flicker Rod XHD23	X-5903090200RP	XHD33L	500001939
XHD26 & XHD28	X-5903090100RP	14. Media Tray XHD23G	X-0442320100RP
XHD33	500001935	XHD26G	X-0442280100RP
9. Flame LED Strip XHD23	X-3002200100RP	XHD28G	X-0442310100RP
XHD26 & XHD28	X-3002200200RP	XHD33G	500001940
XHD33	500001941	15. Medium Ice Chunks (Media Models)	X-1400150100RP
10. Flame Base LEDs XHD23L & XHD26L	X-3001880100RP	16. Large Ice Chunks (Media Models)	X-1400130400RP
XHD28L	X-3001880200RP	17. Front Glass XHD23	X-5903150100RP
XHD33L	500001914	XHD26	X-5903070100RP
11. Media LED Strip XHD23G	X-3001570100RP	XHD28	X-5903160100RP
XHD26G	X-3001570700RP	XHD33	500001938
XHD28G	X-3001570300RP	18. Remote Control	X-6700590200RP
XHD33G (2)	X-3001960100RP	19. Mounting Hardware (XHD26)	X-9602100100RP
		20. Felt Feet Pads	X-8600140101RP

Exploded Parts Diagram

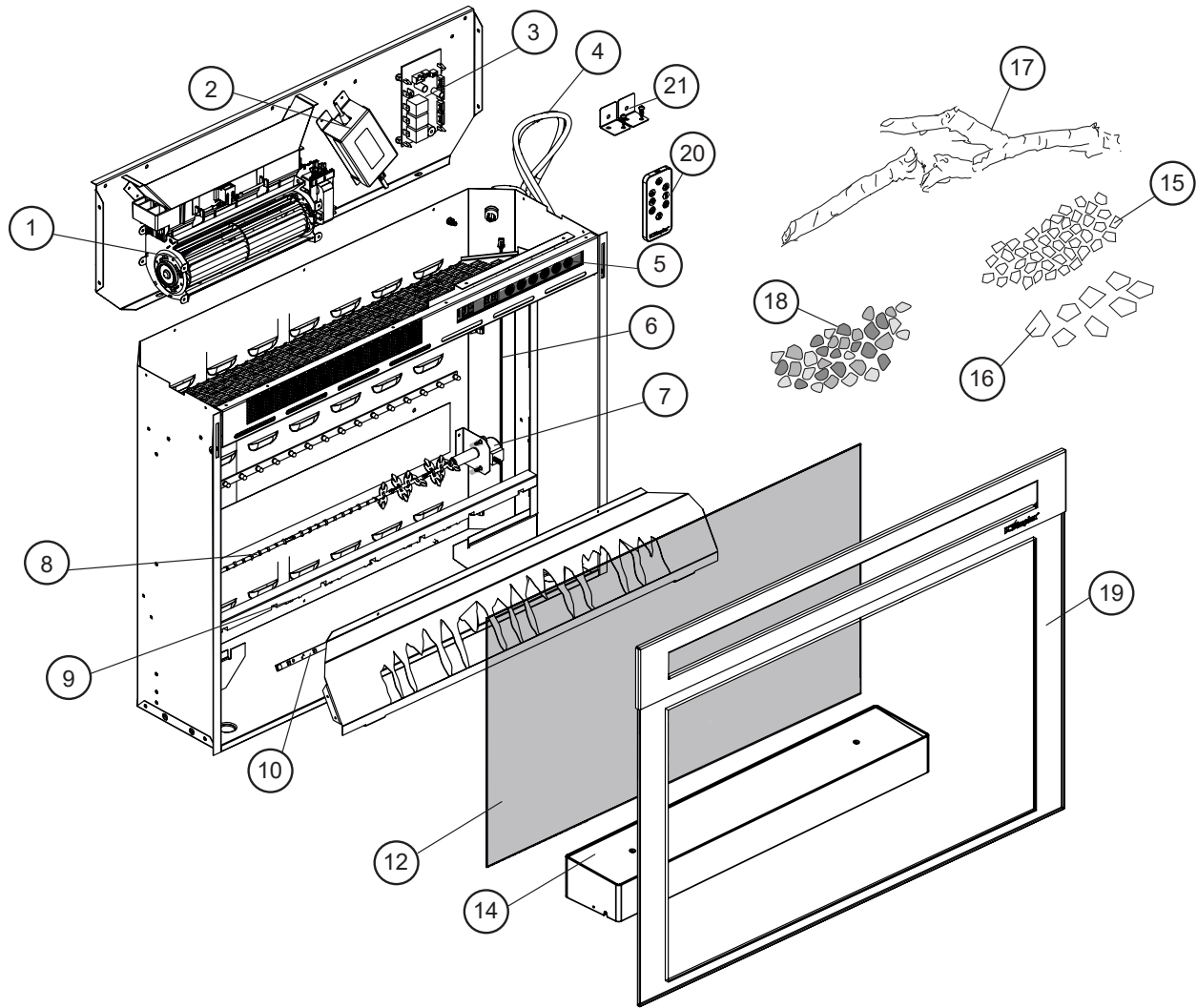

DF-PRO Replacement Parts List

1. Heater Assembly	X-2203730300RP	12. Flame Screen DF26-PRO	X-5902580500RP
2. Power Supply	X-2100250700RP	DF28-PRO	X-5902580600RP
3. Main Control Board Logs	X-3001840100RP	13. Logset DF26L-PRO	X-0442220100RP
DWC	X-3001840200RP	DF28L-PRO	X-0442300100RP
4. Power Cord	X-4100190600RP	14. Media Tray DF26DWC-PRO	X-0442280100RP
5. Touchpad	X-6700600100RP	DF28DWC-PRO	X-0442310100RP
6. Thermistor	X-3001560800RP	15. Medium Ice Chunks (DWC Models)	X-1400150100RP
7. Flicker Motor	X-3000240200KIT	16. Large Ice Chunks (DWC Models)	X-1400130400RP
8. Flicker Rod	X-5903090100RP	17. Driftwood (DWC Models)	X-0441820100RP
9. Flame LED Strip	X-3002200200RP	18. River Rock (DWC Models)	X-1400080301RP
10. Flame Base LEDs DF26L-PRO	X-3001880100RP	19. Front Glass DF26-PRO	X-5903070100RP
DF28L-PRO	X-3001880200RP	DF28-PRO	X-5903160100RP
11. Media LED Strip DF26DWC-PRO	X-3001570700RP	20. Remote Control	X-6700590200RP
DF28DWC-PRO	X-3001570300RP	21. Mounting Hardware (DF-26-PRO)	X-9602100100RP
		22. Felt Feet Pads	X-8600140101RP

Wiring Diagram

XHD23 MOD 0-A
 XHD26 MOD 0-B
 XHD28 MOD 0-A
 ALL DF-PRO

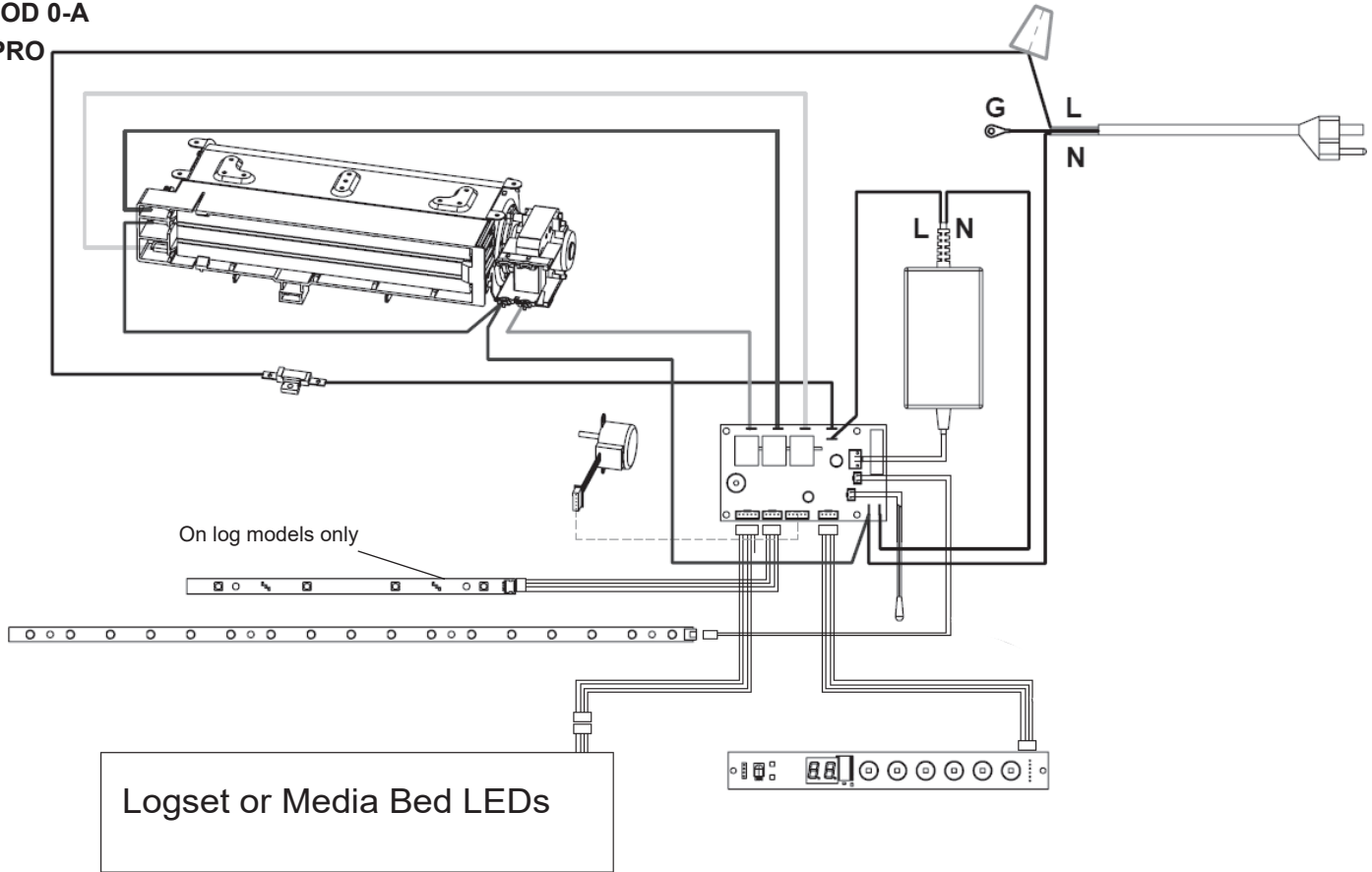

XHD23 MOD B
 XHD26 MOD C
 XHD28 MOD B

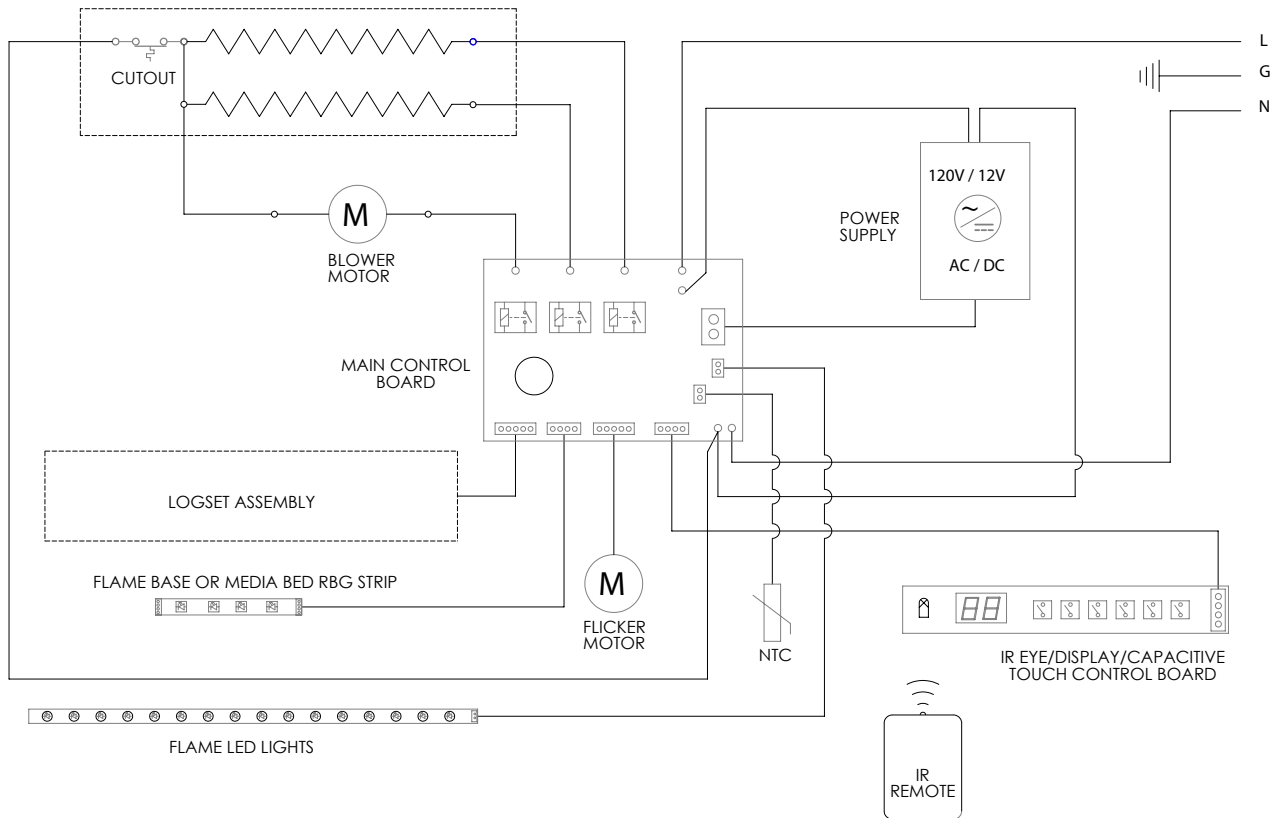

Accessing Top Components

Tools Required: Phillips head screwdriver

⚠ WARNING: If the firebox was operating prior to servicing, allow at least 10 minutes for the heating elements to cool off to avoid accidental burning of skin.

⚠ WARNING: Disconnect power before attempting any maintenance to reduce the risk of electric shock or injury to persons.

1. Unhook the front glass to remove it by pulling it up slightly and pulling it out. Set it aside in a safe place.
2. Remove the firebox from the mantel by removing the retaining screws that secure the firebox to the mantel. These may be located on the inside of the firebox near the front, or behind the firebox if it is secured with L-brackets.
3. Unfasten the top panel by removing the 12 screws located around the periphery of the top panel. There are 2 screws on each side, 3 on the back, and 5 at the very top, directly behind the front flange. Some units may have 6 screws on the top, totaling 13 screws. (Figure 1)
4. Slide the top panel toward the back to release it.
5. Carefully lay the firebox on its back and lay the top cover flat so that the attached components are accessible.

Figure 1

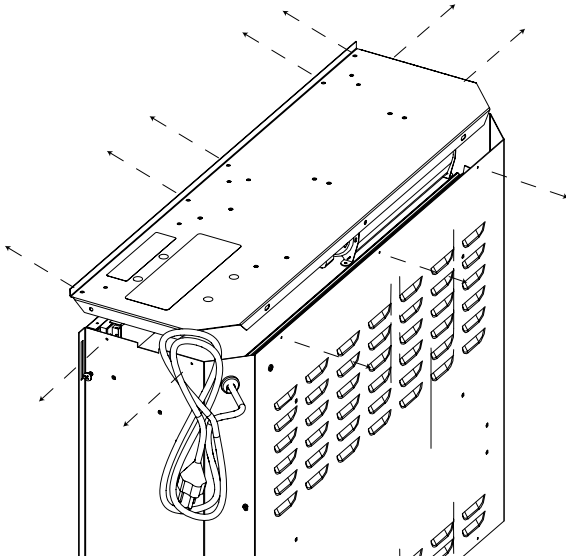

Accessing Bottom Components

Tools Required: Phillips head screwdriver

⚠ WARNING: If the firebox was operating prior to servicing, allow at least 10 minutes for the heating elements to cool off to avoid accidental burning of skin.

⚠ WARNING: Disconnect power before attempting any maintenance to reduce the risk of electric shock or injury to persons.

1. Unhook the front glass to remove it by pulling it up slightly and pulling it out. Set it aside in a safe place.
2. Remove the firebox from the mantel by removing the retaining screws that secure the firebox to the mantel. These may be located on the inside of the firebox near the front, or behind the firebox if it is secured with L-brackets.
3. Unfasten the bottom panel by removing the 11 screws located on the back and sides of the bottom panel. There are 3 screws on the back, and 4 screws on each side. Note that the two middle screws on each side are longer, and hold the media tray or log set in place. (Figure 2)

Figure 2

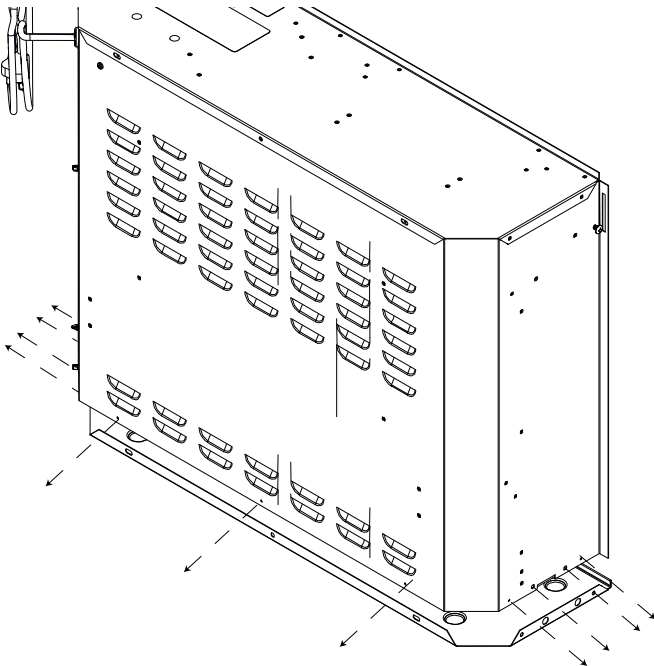

! NOTE: When reinstalling the base panel, align the 2 middle screw holes on each side of the logset/media tray with the corresponding holes on the base panel to ensure that the logset or media tray are properly affixed. (Figure 5)

- Carefully lay the fireplace on its back.
- Remove the bottom panel and set it aside.
 - ! NOTE:** On the XHD28G/DF28DWC-PRO, the media bed lights are attached to this bottom panel. You can disconnect these lights to have better access to the components in the firebox.

! NOTE: The log set/media tray has a wire attached to the unit which can be temporarily disconnected for easier access.

Most components can now be accessed for service. However, if you wish to have further access to the components, complete the following steps.

- Remove the flame screen retaining brackets by removing the 2 screws on each side of the firebox that hold each bracket (4 screws total). (Figure 5)
- Carefully slide the flame screen down toward the base of the firebox and set it aside during service.
 - ! NOTE:** When reinserting the flame screen, ensure that the upper portion is inserted all the way to the top.

Power Cord Replacement

Tools Required: Phillips head screwdriver
Pliers
7mm Wrench

- ⚠ WARNING:** If the firebox was operating prior to servicing, allow at least 10 minutes for the heating elements to cool off to avoid accidental burning of skin.
- ⚠ WARNING:** Disconnect power before attempting any maintenance to reduce the risk of electric shock or injury to persons.

- Follow the instructions for accessing the top components on page 8.
- Disconnect the wires from the powercord, noting their original locations. Use wrench to remove gold nut that secures the green grounding wire to the body of the firebox, along with the silver ring. Cut the cable ties as needed to remove the wires.
- With pliers, grasp the power cord strain relief grommet from inside the back of the bottom panel and push while twisting to remove.
- Install the new power cord and reconnect wires as before. Refer to the wiring diagram if needed. Ensure that they are secure and the wires cannot be pulled out of the wire connector.
 - ⚠ WARNING:** Ensure wires do not come in contact with moving parts by securing wires in cable ties or electrical tape.
- Reassemble the firebox.

Main Control Board Replacement

Tools Required: Phillips head screwdriver
Pliers

- ⚠ WARNING:** If the firebox was operating prior to servicing, allow at least 10 minutes for the heating elements to cool off to avoid accidental burning of skin.
- ⚠ WARNING:** Disconnect power before attempting any maintenance to reduce the risk of electric shock or injury to persons.

- Follow the instructions for accessing the top components on page 8.
 - ! NOTE:** It is recommended to take a picture of the wiring connections on the main control board prior to starting to ensure that all wires are reconnected to the correct place on the board.
- Disconnect all wire leading into the main control board. It may be helpful to use pliers to disconnect the flag connectors. Cut the cable ties as needed to remove the wires.
- Using pliers, pinch each of the four plastic standoffs to depress the tabs while gently lifting the main control board to release it. (Figure 3)
- Properly orient and install the new main control board.
- Reconnect the wiring. Refer to the wiring diagram if needed.
 - ⚠ WARNING:** Ensure wires do not come in contact with moving parts by securing wires in cable ties or electrical tape.
- Reassemble the firebox.

Figure 3

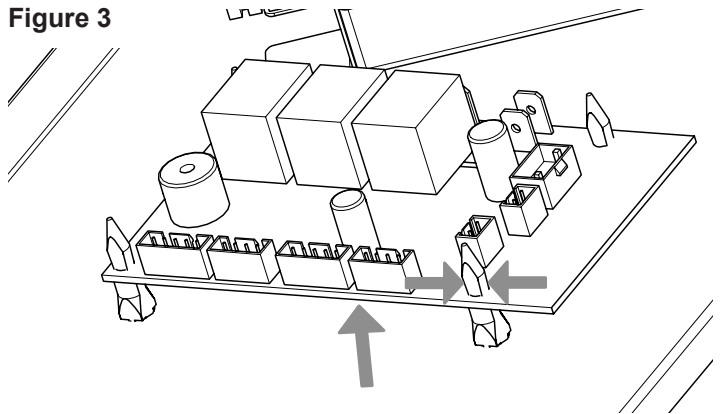

Power Supply Replacement

Tools Required: Phillips head screwdriver
Pliers

⚠ WARNING: If the firebox was operating prior to servicing, allow at least 10 minutes for the heating elements to cool off to avoid accidental burning of skin.

⚠ WARNING: Disconnect power before attempting any maintenance to reduce the risk of electric shock or injury to persons.

1. Follow the instructions for accessing the top components on page 8.
2. Locate the power supply and disconnect the wiring connections, noting their original locations. Cut the cable ties as needed to remove the wires.
3. Remove the 4 screws that secure the power supply holder.
4. Properly orient and position the new power supply and secure it by screwing the power supply holder into its place.
5. Reconnect the wiring. Refer to the diagram if needed.
⚠ WARNING: Ensure wires do not come in contact with moving parts by securing wires in cable ties or electrical tape.
6. Reassemble the firebox.

Heater Assembly Replacement

Tools Required: Phillips head screwdriver
Pliers

⚠ WARNING: If the firebox was operating prior to servicing, allow at least 10 minutes for the heating elements to cool off to avoid accidental burning of skin.

⚠ WARNING: Disconnect power before attempting any maintenance to reduce the risk of electric shock or injury to persons.

1. Follow the instructions for accessing the top components on page 8.
! NOTE: It is recommended to take a picture of the wiring connections on the main control board and heater assembly prior to starting to ensure that all wires are reconnected to the correct place during service.
2. Disconnect the wiring connections noting their original locations. There are 3 on the main control board, 2 wires on the blower motor, and one wire connected with a wire connector. Cut the cable ties as needed to remove the wires.
3. Remove the 4 screws that secure the heater assembly to the top panel. This must be done from the opposite side of the top panel. (Figure 5)
4. Properly orient and install the new heater assembly, and screw it into place.

5. Reconnect the wires. See wiring diagram if needed.
⚠ WARNING: Ensure wires do not come in contact with moving parts by securing wires in cable ties or electrical tape.
6. Reassemble the firebox.

Touchpad Replacement

Tools Required: Phillips head screwdriver

⚠ WARNING: If the firebox was operating prior to servicing, allow at least 10 minutes for the heating elements to cool off to avoid accidental burning of skin.

⚠ WARNING: Disconnect power before attempting any maintenance to reduce the risk of electric shock or injury to persons.

1. Follow the instructions for accessing the top components on page 8.
2. Locate and disconnect the connection from the touchpad to the main control board.
3. Remove screws on either side of the touchpad to release it. (Figure 4)
4. Properly orient the new touchpad and reinsert screws.
5. Reconnect the new touchpad.
6. Reassemble the firebox.

Figure 4

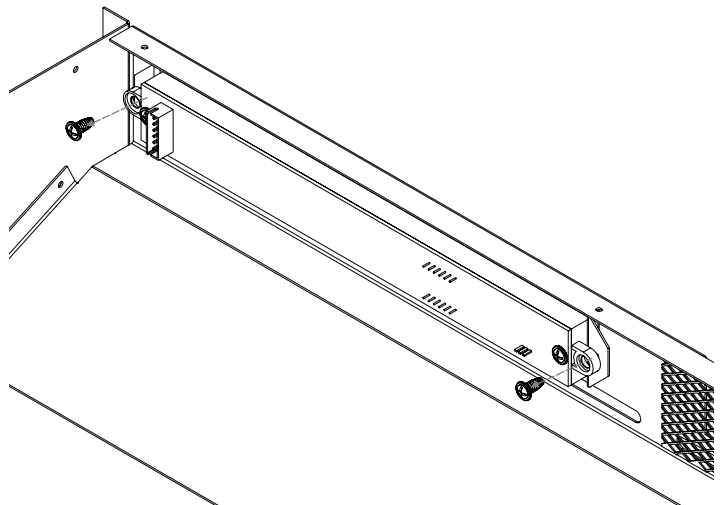

Flicker Motor Replacement

Tools Required: Phillips head screwdriver
Pliers
Side cutters

⚠ WARNING: If the firebox was operating prior to servicing, allow at least 10 minutes for the heating elements to cool off to avoid accidental burning of skin.

⚠ WARNING: Disconnect power before attempting any maintenance to reduce the risk of electric shock or injury to persons.

1. Follow the instructions for accessing the bottom components on pages 8-9.
2. Remove the right side flicker rod retaining bracket by unscrewing the two corresponding screws on the back of the firebox. (Figure 5)
3. Pull the flicker motor out from the rubber coupling attached to the flicker rod.
4. Remove the two screws that affix the flicker motor to the bracket.
5. Cut the five wires as close as possible to the flicker motor.
6. Cut wire leads from the new flicker motor to 3 1/2 inches long.
7. Using one of the supplied wire connectors, connect the yellow wire from the new flicker motor with the yellow wire cut from the old flicker motor.
8. Secure the wire connector by crimping the 3M symbol with pliers. Pull on both wires to ensure a strong connection.
9. Repeat the process for the 4 remaining wires, ensuring that all wires are paired by colour in each connector.
10. Attach new flicker motor to the retaining bracket.
11. Insert stem from flicker rod into the rubber grommet.
12. Reattach the flicker rod retaining bracket.
13. Reassemble the firebox.

Flicker Rod Replacement

Tools Required: Phillips head screwdriver

⚠ WARNING: If the firebox was operating prior to servicing, allow at least 10 minutes for the heating elements to cool off to avoid accidental burning of skin.

⚠ WARNING: Disconnect power before attempting any maintenance to reduce the risk of electric shock or injury to persons.

1. Follow the instructions for accessing the bottom components on pages 8-9.
2. Remove the left side flicker rod retaining bracket by unscrewing the two screws from the back of the firebox. (Figure 5)
3. Pull the old flicker rod out from the rubber grommet.
4. Insert new flicker rod.
5. Place bracket over the end of the new flicker rod and reattach the bracket to the firebox.
6. Reassemble the firebox.

Figure 5

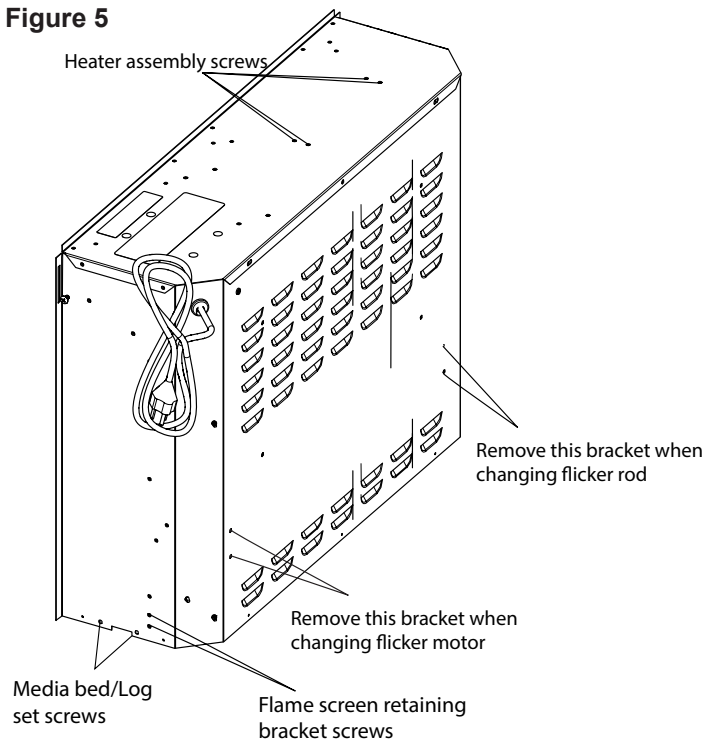

Flame LED Strip Replacement

Tools Required: Phillips head screwdriver

⚠ WARNING: If the firebox was operating prior to servicing, allow at least 10 minutes for the heating elements to cool off to avoid accidental burning of skin.

⚠ WARNING: Disconnect power before attempting any maintenance to reduce the risk of electric shock or injury to persons.

1. Follow the instructions for accessing the bottom components on pages 8-9.
2. Locate the plastic LED holder bar and remove the screw on either side (2 total). (Figure 7)
3. Disconnect the wire(s) that are connected to the LED strip(s) on the LED holder. The LED holder can now be removed.
4. Remove the 4 screws that secure the LED strip to the LED holder. (Figure 6)
5. Install new board by reinserting the screws and connecting the cable(s).
6. Properly orient and install the LED holder, ensuring that the flame LEDs are facing the flicker rod.
7. Reassemble the firebox.

Figure 6

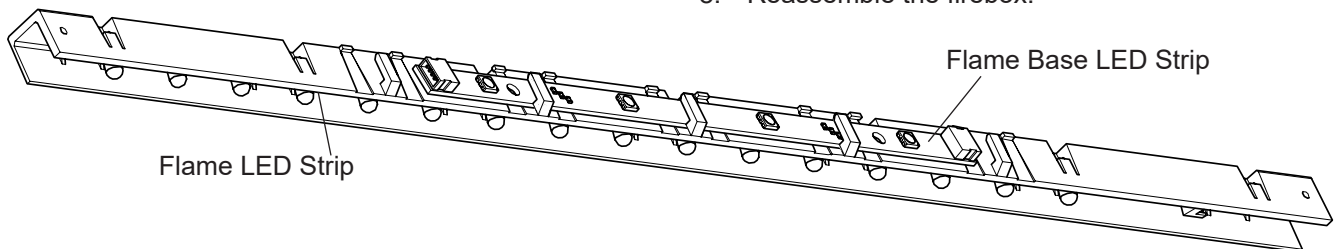

Flame Base LED Strip Replacement

Tools Required: Phillips head screwdriver
Flathead Screwdriver

⚠ WARNING: If the firebox was operating prior to servicing, allow at least 10 minutes for the heating elements to cool off to avoid accidental burning of skin.

⚠ WARNING: Disconnect power before attempting any maintenance to reduce the risk of electric shock or injury to persons.

1. Follow the instructions for accessing the bottom components on pages 8-9.
2. Locate the plastic LED holder bar and remove the screw on either side (2 total). (Figure 7)
3. Disconnect the two cables that lead to the LED strips.
4. The LED holder can now be removed
5. Release the LED strip from the clips: starting at one end of the LED strip, carefully place the head of the flathead screwdriver under the LED strip while gently pulling it up and out to release it from the clips on the LED holder.
6. Snap the new LED strip into place and reconnect the cable. (Figure 6)
7. Connect both cables. Properly orient and install the LED holder, ensuring that the flame base LEDs are toward the base of the firebox and the flame LEDs are facing the flicker rod.
8. Reassemble the firebox.

Media Tray / Media LED Strip Replacement

Tools Required: Phillips head screwdriver

⚠ WARNING: If the firebox was operating prior to servicing, allow at least 10 minutes for the heating elements to cool off to avoid accidental burning of skin.

⚠ WARNING: Disconnect power before attempting any maintenance to reduce the risk of electric shock or injury to persons.

1. Follow the instructions for removing base panel
2. Remove the 2 screws that secure the media LED lights and unplug the board.
3. Align the new board, ensuring that the connector with the marking IN is oriented toward the right-side so that the cable can be reconnected on the correct side. Ensure that the LED lights on the strip are facing the clear plastic face of the tray.
4. Affix the LED strip to the media tray, ensuring that the plastic washers are placed between the LED strip and the screw.

Thermistor Replacement

Tools Required: Phillips head screwdriver
Side cutters

⚠ WARNING: If the firebox was operating prior to servicing, allow at least 10 minutes for the heating elements to cool off to avoid accidental burning of skin.

⚠ WARNING: Disconnect power before attempting any maintenance to reduce the risk of electric shock or injury to persons.

! NOTE: For XHD23/XHD28 MOD B+, XHD26 MOD C+, and XHD33 skip steps 4-6, as the end of the thermistor is located at the top, near the power cord.

1. Follow the instructions for accessing the top components.
2. Locate and disconnect the thermistor connection on the main control board. Cut the cable tie as needed to remove the wire.
3. Connect the new thermistor in the same location.
⚠ WARNING: Ensure wires do not come in contact with moving parts by securing wires in cable ties or electrical tape.
4. Drop the cable for the old thermistor, as well as the wire of the new thermistor down at the same location as the old thermistor, so that they will be accessible from the bottom.
5. Reassemble the top cover.
6. Follow the instructions for accessing the bottom components on pages 8-9.
7. Snip the cable tie that affixes the thermistor to the firebox.
8. Affix the new thermistor to the firebox, using the provided cable tie.
9. Reassemble the firebox.

Flame Screen Replacement

Tools Required: Phillips head screwdriver

⚠ WARNING: If the firebox was operating prior to servicing, allow at least 10 minutes for the heating elements to cool off to avoid accidental burning of skin.

⚠ WARNING: Disconnect power before attempting any maintenance to reduce the risk of electric shock or injury to persons.

1. Follow steps 1-7 for accessing the bottom components
2. Slide new flame screen up, ensuring that the flame screen is fully inserted.
3. Reassemble the firebox.

Log Set Replacement

Tools Required: Phillips head screwdriver

⚠ WARNING: If the firebox was operating prior to servicing, allow at least 10 minutes for the heating elements to cool off to avoid accidental burning of skin.

⚠ WARNING: Disconnect power before attempting any maintenance to reduce the risk of electric shock or injury to persons.

1. Follow the instructions for accessing the bottom components on pages 8-9.
2. Disconnect the cable from the log set by depressing the three tabs and pulling both ends away from each other.
3. Connect the new cable, and orient the log set along the base of the fireplace.
4. Reassemble the firebox.

Figure 7

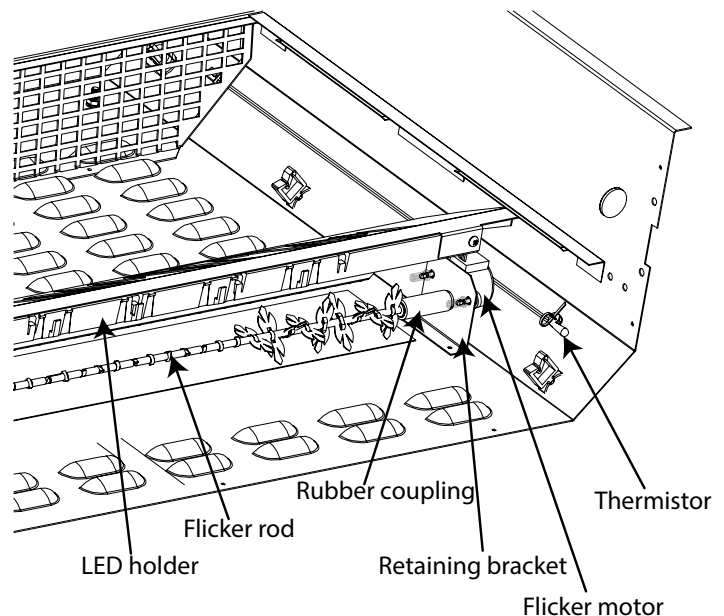

Troubleshooting Guide

PROBLEM	CAUSE	SOLUTION
General		
Circuit breaker trips or fuse blows when unit is turned on	Improper circuit current rating	Additional appliances may exceed the current rating of the circuit breaker or fuse. Plug unit into another outlet or install unit on a dedicated 15 amp circuit.
	Short in unit wiring	Trace wiring in unit
Power cord gets warm	Normal operation	The power cord may get slightly warm to the touch when the heater is on.
	Defective power cord	Replace power cord
Firebox does not turn on using the manual controls	Improper operation	Refer to operation section
	No incoming power from the electrical wall socket	Check fuse/breaker panel
		Ensure the unit is not plugged into a power bar, surge protector, extension cord, etc.
	Defective main control board	Replace main control board
	Loose touchpad connection	Check touchpad connection
	Defective touchpad	Replace touchpad
	Defective power supply	Replace power supply
Firebox does not respond to the remote control	Batteries need to be replaced	Change batteries (see Maintenance section)
	Defective remote control	Replace remote control
	Defective touchpad	Replace touchpad
Firebox turns off shortly after being powered on	Defective power supply	Replace power supply
Appearance		
Log set dim or not glowing	Loose connection	Check wiring connections
	Defective log set	Replace log set
Flame not visible	Flame is turned off (log models only)	Ensure colour theme is not set to t0
	Defective flame LED strip	Replace flame LED strip
	Defective main control board	Replace main control board
Left half of flame not visible	Broken flicker rod	Replace flicker rod
Media is not illuminated	Unit is set to midnight mode	Ensure colour theme is not set to t0
	Defective media LED strip	Replace media LED strip
	Defective main control board	Replace main control board
Display is flashing	Loose wiring	Check wiring connections
	Defective power supply	Replace power supply
	Defective main control board	Replace main control board
Flame is frozen	Defective flicker motor	Replace flicker motor
	Defective main control board	Replace main control board
Light is leaking out around the log set	Log set is not positioned properly in the unit	See instructions for replacing log set. Ensure logset is connected to base panel.

Heater		
Heater is not turning on	Set temperature is below room temperature	See operation instructions
	Heat is disabled; --- is displayed when heat button is pressed	See operation instructions
	Defective heater assembly	Replace heater assembly
	Defective main control board	Replace main control board
Heater cuts out after a short time	Inadequate air circulation	Ensure that there is sufficient space around the firebox. Install feet if necessary.
	Buildup of dust/debris	Ensure that the exterior intake louvers and firebox cavity are free of dust/debris
	Defective heater assembly	Replace heater assembly
Noise		
Excessive noise when the heater is on	Buildup of dust/debris in the heater assembly	Ensure that the exterior intake louvers and firebox cavity are free of dust/debris
	Defective heater assembly	Replace heater assembly
Excessive noise when flames are on	Flicker rod is hitting or rubbing against internal component	Ensure that the flicker rod is straight and mounted properly in the bracket; and spinning freely away from other components. Replace the flicker rod if necessary.
	Defective flicker motor	Replace flicker motor

Demo Mode

Certain versions of this firebox are equipped with a demo mode where the unit cycles through several functions. The demo mode is activated by pressing and holding the temperature and brightness buttons for 2 seconds. In demo mode, the display remains lit and none of the remote or on-unit controls work. When power is cut to the unit and then restored, the unit remains in demo mode.